

Technical Documentation

De-Mystifying AutoCAD Plant 3D Isometrics

Configuration Reference

1 Table of Contents

De-Mystifying AutoCAD Isometrics	1
1 Table of Contents.....	2
Overview	4
2 Getting Started on AutoCAD Isometrics	5
2.1 Isometric Structure.....	5
2.2 Creating a company style	5
2.2.1 Creating a new Style.....	5
2.2.2 Testing Isometric Output.....	6
3 Title Block	9
3.1 Title Block Insertion.....	9
3.2 Attribute Setup.....	9
3.2.1 LDT Setup.....	9
3.2.1.1 LDT Overview	9
3.2.1.2 P&IDs with an LDT.....	9
4 Themes.....	13
4.1.1 Overview.....	13
4.1.2 Default	13
4.1.3 Override.....	14
5 Symbols.....	16
5.1 Default Symbol Keys.....	16
5.2 Default Symbol Blocks.....	24
5.3 Default Symbol Types.....	33
5.4 Creating Custom Symbols	34
5.4.1 Creating a symbol	34
5.4.2 Create the symbol key reference	35
5.5 Assigning Custom Symbols.....	35
6 Advanced Isoconfig.xml Techniques.....	38
6.1 What is the isoconfig.xml	38
6.1.1 Viewing XML files	38
6.1.2 XML Notepad 2007.....	39
6.1.3 Foxe	39
6.1.4 Iso Configuration Editor.....	40
6.2 Iso Config Sections	41
6.2.1 Sections governed by Plant 3D.....	41
6.2.1.1 TitleBlockArea	41

6.2.1.2	Skew	42
6.2.1.3	TableSchemes	43
6.2.1.4	Title block Attributes.....	47
6.2.2	Core Internal Sections	47
6.2.2.1	Split	47
6.2.2.2	Data – Controlling Material, Weld, Spool, and Cut List Content	49
6.2.2.3	Table.....	52
6.2.2.4	Titleblock.....	53
6.2.2.5	Filters.....	53
6.3	Display Settings	54
6.3.1	Dimensions	54
6.3.2	Annotations	55
6.3.2.1	Annotation Leader Styles.....	56
6.3.2.2	Annotation Styles.....	57
6.3.2.3	Annotation Schemes	57
6.4	Key Concepts	59
6.4.1	Model Properties.....	59
6.4.2	Line Group Properties	59
6.4.3	Project/Drawing Properties.....	59
6.4.4	Attribute Mapping.....	60
7	Customization Examples	61
7.1	Modifying Dimension Cutoff	61
7.2	Modifying Isometric file Names	61
7.3	Using Lower Case Characters	63
7.4	Turning Off Coordinates.....	64
7.5	Changing the Line Number Callout	65
8	Using AutoCAD Isometrics	67
8.1	Production Workflow	67
8.2	Figures	68
	Revision History	71

Overview

AutoCAD Isometrics are a powerful tool that can boost your design production. This paper is going to introduce the core concepts of AutoCAD isometrics, and expand on the setup to implement advanced features. We will cover options that are available through the project setup dialog, explore creating a title block setup, learn how to test the isometric output, expose features available only through the isoconfig.xml, and document a workflow for managing your isometrics.

2 Getting Started on AutoCAD Isometrics

2.1 Isometric Structure

The isometric structure is centered on styles. Like dimension, annotation, and multi-leader styles, isometric styles determine the color, layout, and structure of your isometrics. The default styles, Check, Final, Spool, and Stress, provide a look at options you want to keep open for your styles.

Figure 1 Iso Style Settings

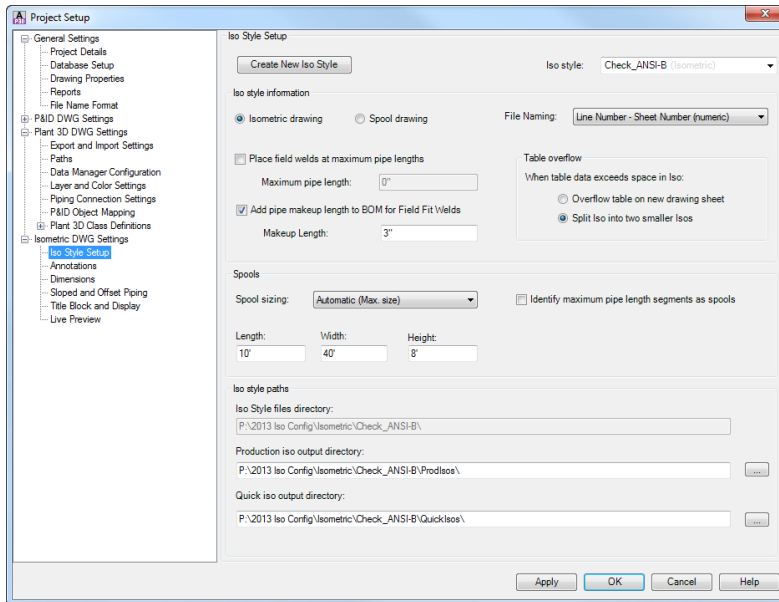

2.2 Creating a company style

2.2.1 Creating a new Style

To create a new style, click the Create New Iso Style button in the top left of the Iso Style Setup dialog.

Figure 2 Create new Iso Style button

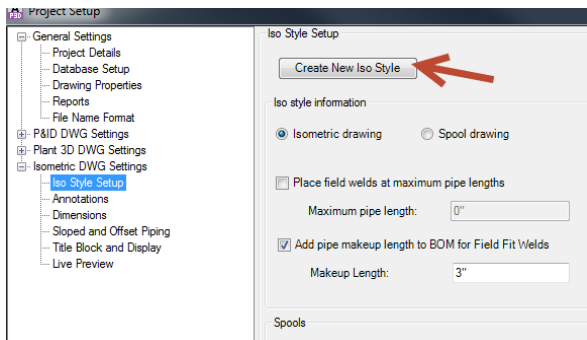

Typically you create a new style if you want to use a specific style name, or you need to produce isometrics that look different while preserving the default style options.

2.2.2 Testing Isometric Output

In addition to creating a standard company style, you should create a test style. A test style is helpful for identifying model information that would typically not show up in a standard iso style. For example, when troubleshooting models, having a style that outputs coordinates for every component helps locate items with wrong line numbers.

At a minimum your test style should include coordinates for every component. While generating an iso for a typical line, the isometric will be extremely cluttered; however, for instances when a component like a weld has a wrong line number, having the coordinates of that weld will save a lot of time locating the object.

First create a new iso style called Test_ANSI-B, using the Check_ANSI-B style as a template.

Figure 3 Create Test_ANSI-B

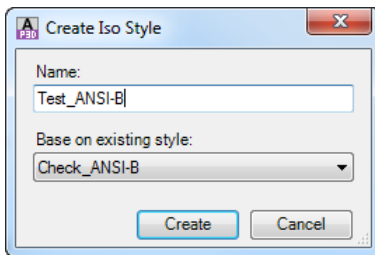

Click ok, to save the changes in the project and close the Project Setup dialog. Navigate to the Test_ANSI-B folder in your project, and open the isoconfig.xml. You will need an XML editor or notepad to modify XML files (For this document I will use [Foxe](#)). You must never edit an xml file while the project setup dialog is open as you will lose any customizations.

In Your XML editor, go to Themes > Annotations > AnnotationSchemes, and copy the FieldWeld ComponentScheme. Right-click on the same node, and choose Paste After.

Figure 4 Copying a ComponentScheme

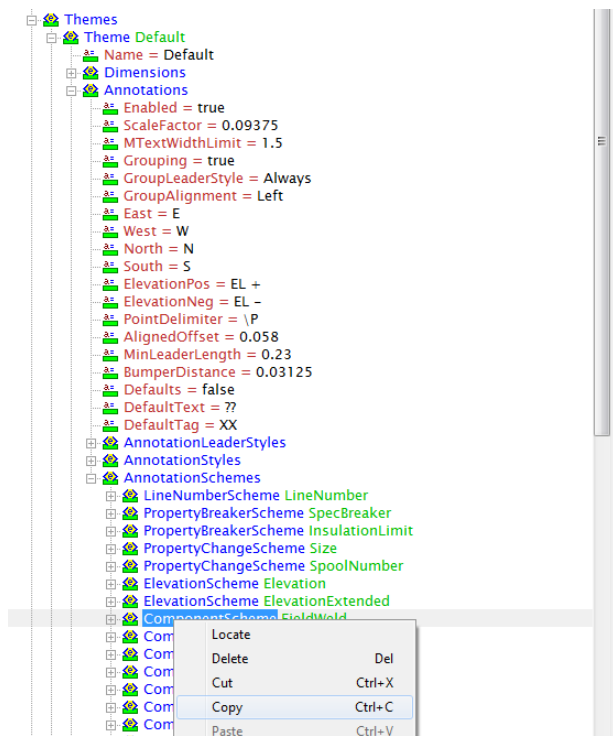
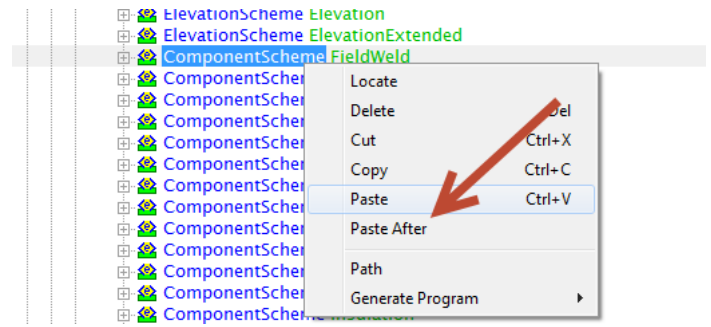

Figure 5 Duplicating a ComponentScheme



After duplicating the ComponentScheme, we need to modify it to place coordinates. Change the Name to PlaceCoords, change the Format to "{0}", Filter to "AnyItem", Fields to "CO-ORDS", and Placement to "Along"

Save your changes and run a test iso. You should get output similar to this where every component has its coordinates listed.

3 Title Block

3.1 Title Block Insertion

See the [isoconfig.xml title block section](#) for details on inserting your own title block. If you don't modify the isoconfig.xml, follow these steps:

1. Insert your title block drawing into the isometric template.
2. Erase the existing Title Block reference.
3. Purge the Title Block block definition.
4. Use the RENAME command to change your company title block name to "Title Block".

3.2 Attribute Setup

3.2.1 LDT Setup

3.2.1.1 LDT Overview

A Line Designation Table (or LDT) allows you to create and modify information external to Plant 3D, but include the information on an isometric. Originally, line designation tables were comma delimited (.csv), but now they are Excel Spreadsheets (.xls, .xlsx). After locating the ldt file, the project setup will read the given file and allow you to locate the position of the attributes corresponding to the columns in your LDT. Then, you will choose which column includes the line number (the unique numeric value) for lookup. When the isometric is created, the file will be scanned for the current line number, and the column values for the corresponding row will be inserted into the isometric.

3.2.1.2 P&IDs with an LDT

For maximum benefit, the P&IDs can be used as a basis for the LDT. When using AutoCAD P&ID for an LDT, you should create the properties that should be in the LDT at the P&ID Line Group class level.

Figure 10 Pipe Line Group Properties

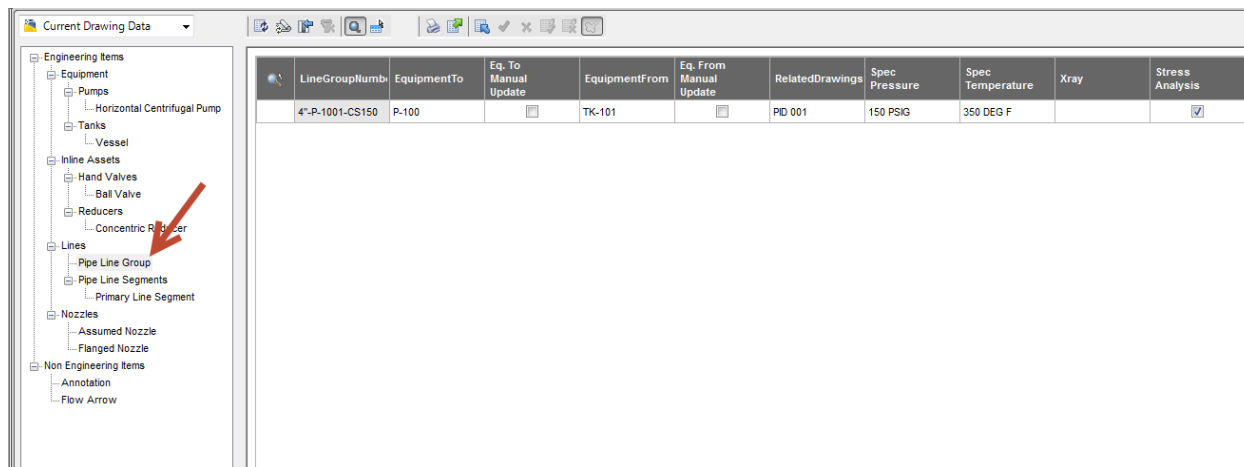

For common fields like Equipment To and From, and related P&ID drawings, you can use the [PDO Extended Fields](#) plugin which will populate the fields based on the drawing data.

To create the LDT from the P&ID Line Groups for your project, open the Data Manager, select Project Data, then right-click on Line Group class and choose Export. In the Export Data dialog, check Active Node only and select an appropriate location for your spreadsheet.

Figure 11 Choosing P&ID Project Data

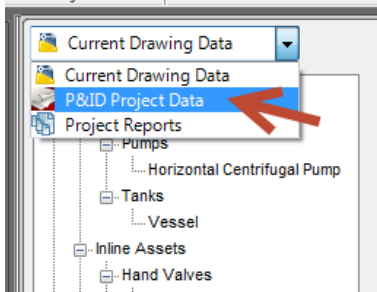

Figure 12 Exporting Pipe Line Group Data

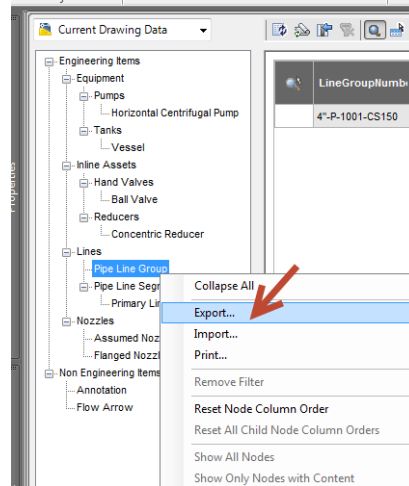
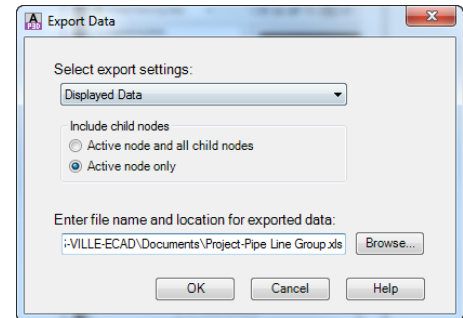

Figure 13 Export Active Node Only



After the line group data is exported, you can set up your title block. Go to Setup Title Block in Project Setup.

Figure 14 Setup Title Block

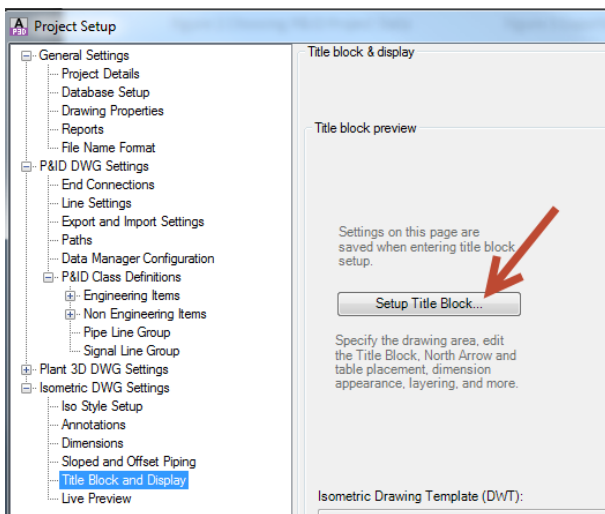
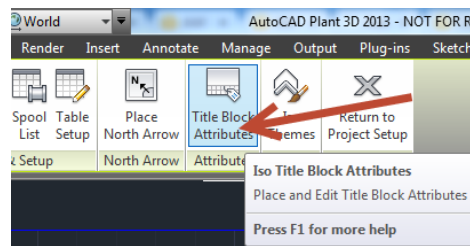

Figure 15 Title Block Attributes Navigation



In the title block setup, go to Table Setup.

Switch to the LDT Tab, and browse to the Excel spreadsheet you created. You can click view LDT to make sure the information was chosen correctly. The Line number column should match the value of the Tag being used for the P3D Line Group (for example: in the line number column put in column ids (A, B, C, ...) not the text of first row of the column).

Figure 16 P3D Line Group Tag Format

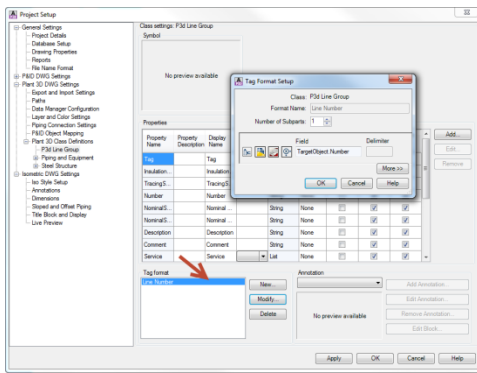
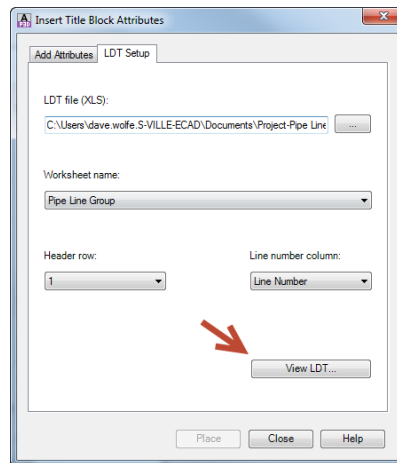

Figure 17 View the LDT



After selecting the line number column, switch back to the Add Attributes tab to place the attributes from the LDT. Switch the Attribute category to LDT Attributes, and place the attributes using the format options and selecting the attribute listed. After inserting your attributes, running your iso should give you the properties needed in the correct locations.

Figure 18 Titleblock with LDT Attributes Placed

	SERVICE	Service	PROJECT NAME:	Proj
	PIPE SPEC	NominalSpec	TITLE:	Project
	MAX PRESSURE	SpecPressure	DRAWING NUMBER:	D
	MAX TEMPERATURE	SpecTemperature	LINE NO:	A
	P&ID DWG	RelatedDrawings	LINEGROUPNUMBER	
	INSULATION SPEC	InsulationSpec	JOB NUMBER:	E
P&ID	INSULATION THK	InsulationThickness	Project_Number	

Figure 19 Generated Titleblock with LDT Attributes from P&ID

		PROJECT NAME:	_20
		TITLE:	
	150 PSIG	DRAWING NUMBER:	
RE	350 DEG F	LINE NO:	4"-P-1001-CS150
	PID 001	JOB NUMBER:	

4 Themes

4.1.1 Overview

Themes control how piping objects and annotations get displayed on the isometric. In addition to controlling the layer and color of items, themes control how the annotations are used, and what elements belong in annotations. The base theme for isometrics is the Default theme. While the default theme governs general output, Plant 3D provides Override themes to change the display for specific sets of items. Using a combination of the Default theme and override themes, give Plant 3D isometrics a wide range of customization.

Theme Editing is available in part in the Title block setup.

Figure 20 Iso Themes Editor

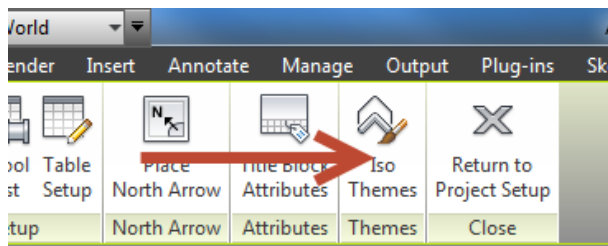

4.1.2 Default

The Default theme contains the sections that govern aspects of the isometric. Some of the sections are Dimensions, Annotations, BendElbow, Symbols, and Insulation.

In the Default Theme tab, we can edit which styles are assigned in the default themes, whether annotations appear, annotation text size, whether dimensions are enabled, and symbol scale.

Figure 21 Default Theme Editing

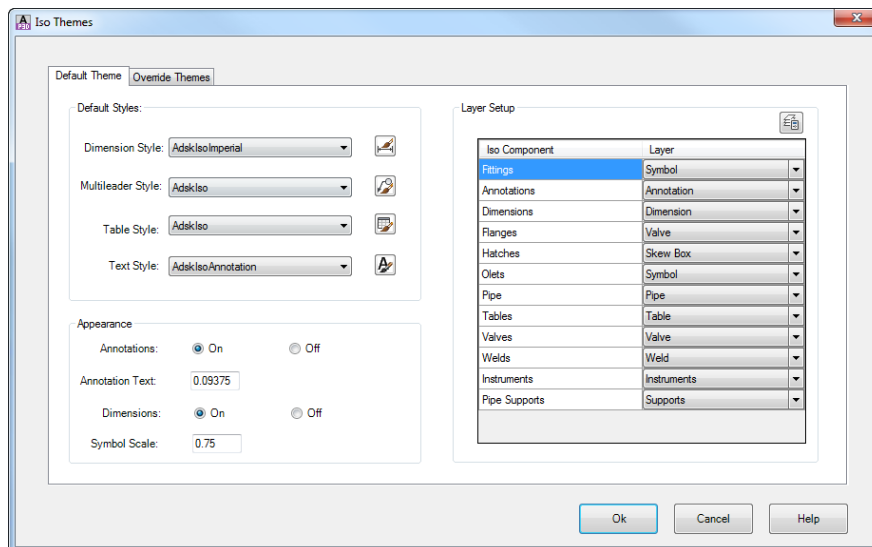
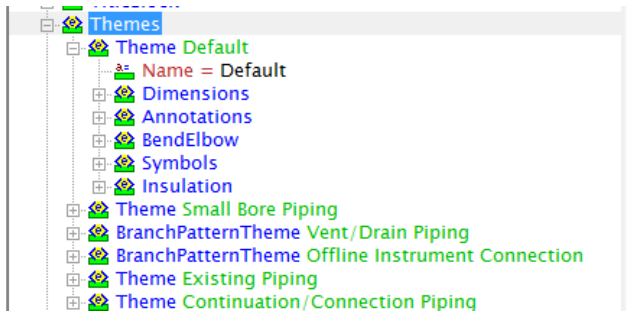

Figure 22 Default Theme Sections



4.1.3 Override

When an isometric is created, the default theme governs the basic item look. However, the isoconfig.xml also contains override themes. Override themes allow us to specify special settings for specific set of objects. For example, the Small Bore Piping theme is applied to objects that can be selected using the SmallBorePiping filter (see the [Filters](#) section).

Figure 23 Small Bore Piping Theme

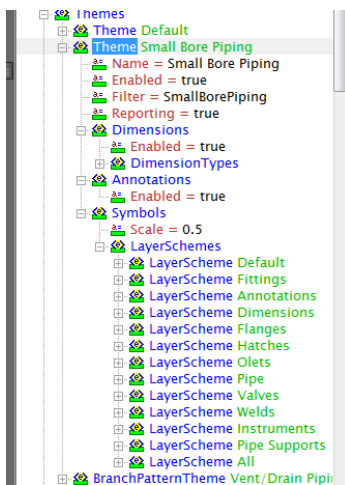

Within the Small Bore Piping theme, we have Dimension, Annotations, and Symbols sections. For all of these sections, we can modify settings in the title block setup under themes.

The override themes tab allows us to control similar options for override themes. However, we can't modify which styles are used, but we can modify layers separately. While these settings apply for all override themes, by examining the xml for the override themes, we see more of the options that are available (especially the continuation theme).

Figure 24 Override Theme Editing

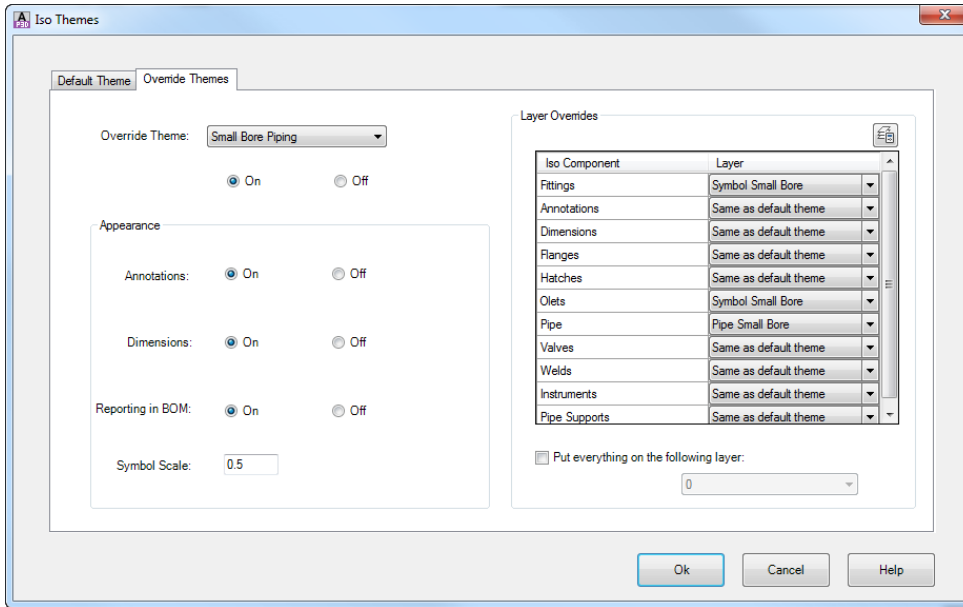
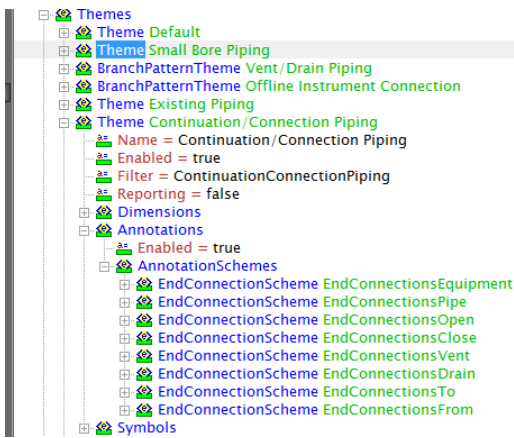

Figure 25 Continuation Theme XML



5 Symbols















Like a P&ID, isometrics are composed of symbols. The program includes a default list of symbols. In order to apply a symbol to a specific part, each symbol is assigned a symbol key. While a symbol key indicates what a component's representation is on an isometric, the type tells the program how other component data should be applied. This chapter documents the currently available symbol keys, the currently used types, and how to create and apply a new custom symbol.









5.1 Default Symbol Keys















While a comprehensive symbol list is not available, a general list of the default values included in each project are below.















The list is compiled from the default IsoSkeyAcadBlockMap.xml.















Symbol	SKEY	Block Name	Image	Default Type
Elbow	EL??, EB??	Elbow		ELBOW
Reducing Elbow	ER??	ElbowReducing		ELBOW
Bend	PB??, BE??	Bend		BEND
Mitered Bend	MI??	BendMitre		BEND
180 Elbow Return	EU??	Elbow-180return		ELBOW
180 Bend Return	BU??	Bend-180return		BEND
Tee	TE??, TY??	Tee		TEE
Tee Bend	BT??	TeedBend		TEE
Concentric Reducer	RC??, CPBW, CS??, RB??	ReducerConc		REDUCER-CONCENTRIC
Eccentric Reducer	RE??, ESBW	ReducerEcc		REDUCER-ECCENTRIC







Symbol	SKEY	Block Name	Image	Default Type
Gasket	GASK	Gasket		
Filter Strainer	FI??	Filter-Strainer		FILTER
Angle Filter	FA??	Filter-Angle		FILTER
Cross	CR??	Cross		CROSS
Union	UN??	Union1		UNION
Coupling	CO??	Coupling		COUPLING
Screwed Coupling	COSC	ScrewedCoupling		COUPLING
Compression Coupling	CSCP	Coupling-Compression		COUPLING, REDUCER- CONCENTRIC
Cap	KABW	Cap		CAP
Screwed Cap	KASC, KASW, KAGL, KAPF	ScrewedCap		CAP
Clamped Cap	KASC, KASW	ClampedCap		CAP
Non-catalog Item	NC??	NonCatItem		MISC- COMPONENT
Nip-o-let	NI??	Nipolet		OLET
Nipple	NR??	Nipple		COUPLING

Symbol	SKEY	Block Name	Image	Default Type
NippleBS	NB??	NippleBS		COUPLING
Orifice Plate	OP, PR	Orifice-RestrictorPlate		INSTRUMENT
Plug	PL	Plug		MISC-COMPONENT
Male Blanking Plug	BM	MaleBlankingPlug		MISC-COMPONENT
Open Spectacle Blind	SB	Fig8BlindOpen		MISC-COMPONENT
Spectacle Blind	SP	Blind		MISC-COMPONENT
Spacer	SR	Spacer		MISC-COMPONENT
Pipe Block	PF	PipeBlock		
Trap	TI??	Trap		
Male to Male Adapter	ADMM	M_M_Adapt		
Male to Female Adapter	ADMF	M_F_Adapt		
General Olet	SKSW, TH??,WTBW	Olet1		OLET
Half-Coupling Olet	HC??	Olet-Half Coupling		OLET
Latrolet	LA??	Latrolet1		OLET
Ferrule Flared	FE??	Ferrule-Flared		

Symbol	SKEY	Block Name	Image	Default Type
Flange	FLSO, FOSO, FLSI, FLBL, FLSW, FLRC	Flange		FLANGE
Weld Neck Flange	FLWN, FOWN	FlangeWN		FLANGE
Fitting Flange	FLFL, FLLB	FittingFlange		FLANGE
Stub End	FLSE	Stub-End		LAPJOINT- STUBEND
Lined Flange	FLGM	Flange-Lined		FLANGE
Screwed Flange	FLGL, FLPF, FLSC	FlangeScrewed		FLANGE
Clamped Flange	FLCL	ClampedFlange		FLANGE
Filter with Offset	FO??	Filter-Offset		FILTER
3 Way Valve	V3??	3WayValve		VALVE-3WAY
4 Way Valve	V4??	4WayValve		VALVE-4WAY
Angle Valve	AR??, CAFL, RA??, AV??	ValveAngle		VALVE-ANGLE
Ball Valve	VB??	BallValve		VALVE
Butterfly Valve	VY??	ButterflyValve		VALVE
Butterfly Valve 2	ZB??	ButterflyValve1		VALVE
Check Valve	CK??	CheckValve-Alt1		VALVE



Symbol	SKEY	Block Name	Image	Default Type
Swing Check Valve	VC??	CheckValveArrowed		VALVE
Diaphragm Valve	VD??	Diaphragm Valve		VALVE
Gate Valve	VT??, VV??, CV??, VS??, VP??, VR??	GateValve		VALVE
Globe Valve	VG??	GlobeValve		VALVE
Needle Valve	NV??	NeedleValve		VALVE
Expansion Bellows	EX??	ExpanBellows		
Hand Operator	01SP, 05SP	Operator_Hand1		
Spring Operator	02SP	Operator_Spring		
Lever Operator	03SP	Operator_Lever		
Diaphragm Operator	04SP, 13SP	Operator_Diaphragm		
Operator Hand 2	06SP	Operator_Hand2		
Plug Operator	07SP	Operator_Plug		
Slide Operator	08SP	Operator_Slide		
Operator Alt 1	09SP	Operator_Alt1		
Operator Alt 2	10SP	Operator_Alt2		

Symbol	SKEY	Block Name	Image	Default Type
Operator Alt 3	11SP	Operator_Alt3		
Operator Alt 4	12SP	Operator_Alt4		
Operator Alt 5	14SP	Operator_Alt5		
Operator Alt 6	15SP	Operator_Alt6		
Support	SUPP	Support		SUPPORT
General Support	01HG	Support-General		SUPPORT
Anchor	ANCH	Support-Anchor		SUPPORT
Guide	GUID	Support-GUID		SUPPORT
Spring	SPRG	Support-Spring		SUPPORT
Dummy Leg	DUCK	Support-Leg1		SUPPORT
Hanger	HANG	Support-Hanger1		SUPPORT
Skid	SKID	Support-SKID		SUPPORT
Support on Support	PSIG	Support-Secondary	.	
Pipe End Connection	END-CONNECTION-PIPELINE	SplitMark		
Equipment Connection	END-CONNECTION-EQUIPMENT	EndEquipment		

Symbol	SKEY	Block Name	Image	Default Type
Tap Connection	TAP-CONNECTION	EndTapping		
Split Mark	ISO-SPLIT-POINT	SplitMark		
Instrument Tee	ITFL	Instrument-Tee		INSTRUMENT
Inline Instrument	II??	Instrument-Inline		INSTRUMENT
Flow Arrow	FLOW	FlowArrow		FLOW-ARROW
Floor Symbol	FLOR	Floor_Symbol		FLOOR-SYMBOL
Reinforcement Pad	RPAD	ReinforcementPad	..	

Where the SKEY uses ??, you may specify an end type key from the end types list. This list is also stored in the IsoKeyAcadBlockMap.xml and is configurable. A reference to what end code abbreviations mean may be retrieved by using the PLANTENDCODES command to display the end code list.

End Type	SKEY	Block	Image
Field Weld	WF, WS	FieldWeld	
Weld	WW, SO, WN, SJ	Weld	
Buttweld	BW, BV	Buttweld	
Socket Weld	SW	SocketWeld	
Glued	GL	Glued	
Threaded	SC	Thread	

Flanged Fitting	FL	FittingFlange	
Flared End	FA, TC	FlareEnd	
Clamped	CL	Clamp	

Operators are related to valves using the following settings from the IsoSkeyAcadBlockMap.xml

Spindle Skey	Valve Skey
01SP	AV??, VV??, VD??, VG??, VT??, V3??, V4??,
08SP	VS??
03SP	VB??, VY??, VK??
07SP	VP??
13SP	CV??
02SP	VR??
10SP	ZB??

5.2 Default Symbol Blocks

Supplementing the skey/symbol information is a list of the default blocks. Browsing this list will show you what parameters are used in each block. Block images are linked from their symbol keys above. Below is a list of blocks that are typical of their category.

Category	BlockName
2 Port items	Filter-Strainer
Valve	BallValve
Olet	Nipolet
Operators	Operator_Hand1
Supports	Support

The list below is of the more complicated blocks that demonstrate unique features. For parameter details see [FAQ: How do I create a custom Iso symbol?](#)

Figure 26 Elbow

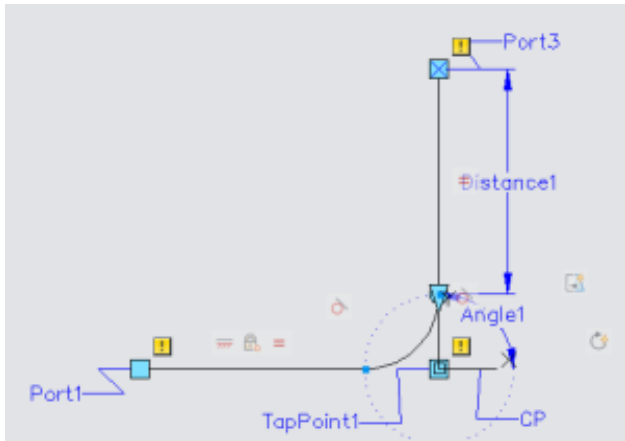

Figure 27 ElbowReducing

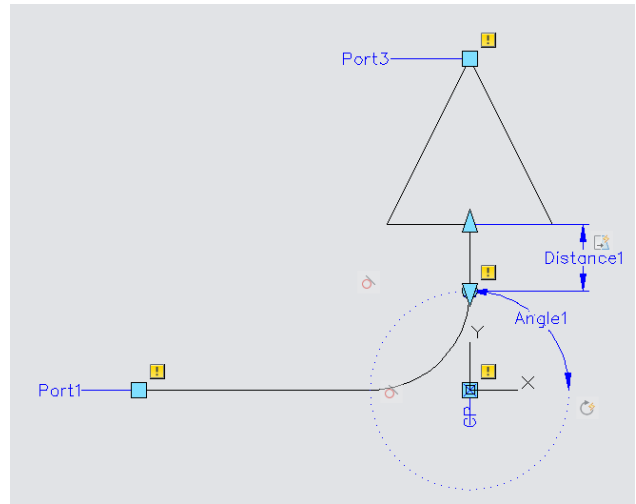

Figure 28 Bend

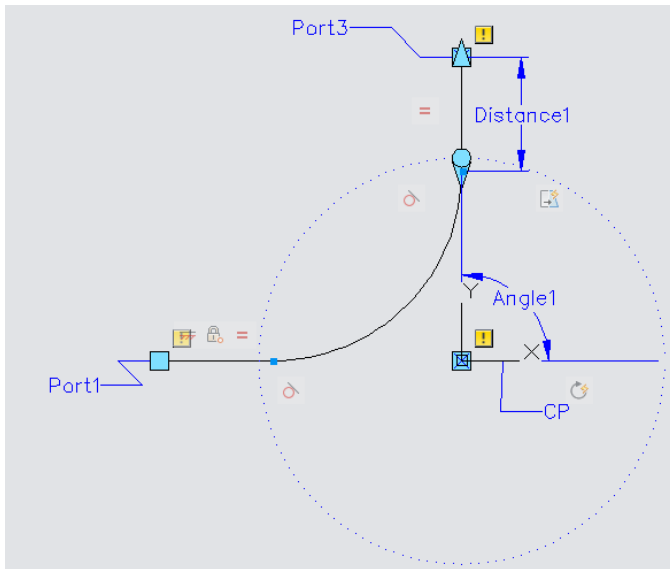

Figure 29 BendMitre

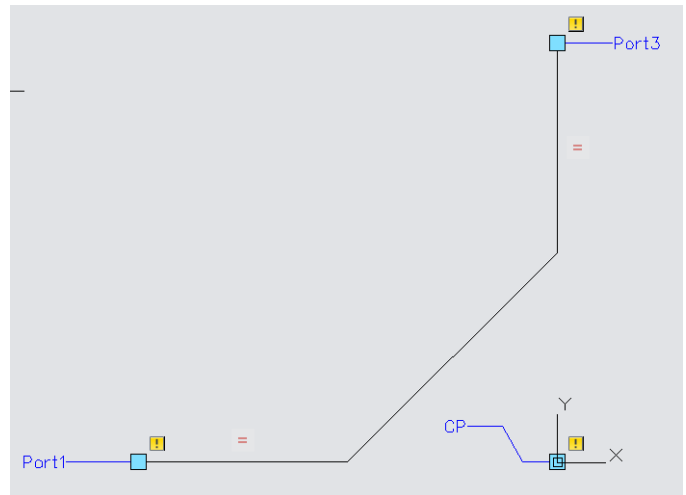

Figure 30 Elbow-180return

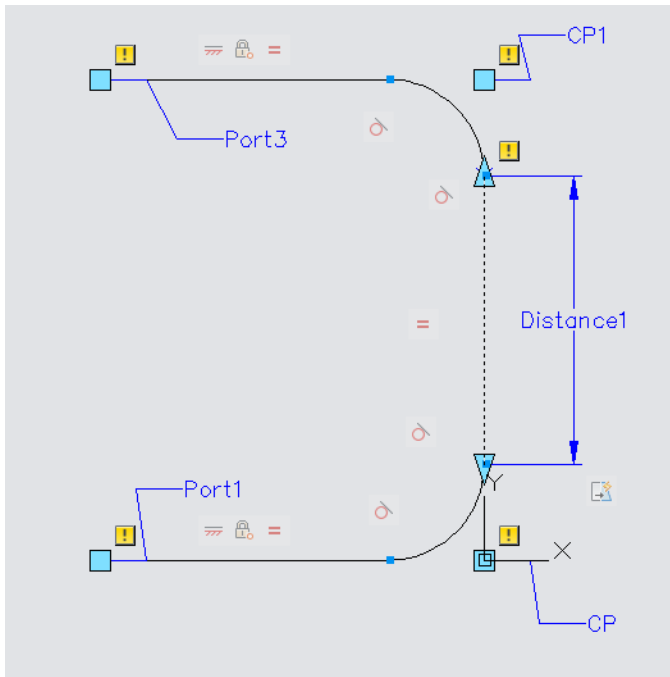

Figure 31 Bend-180return

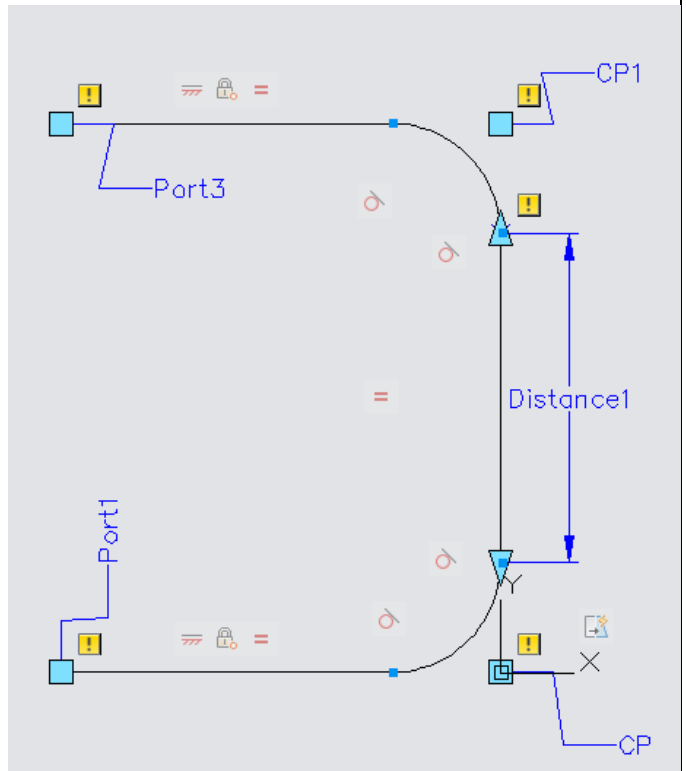

Figure 32 Tee

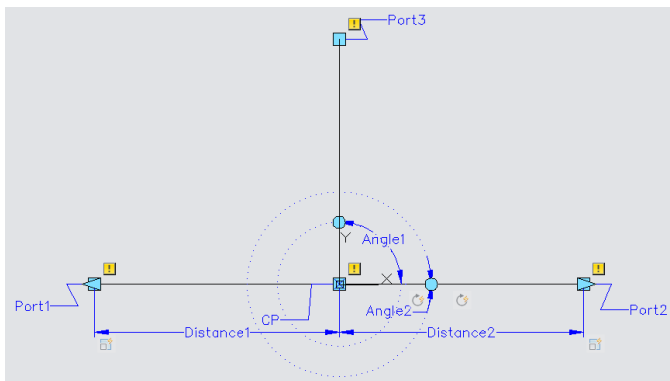

Figure 33 TeedBend

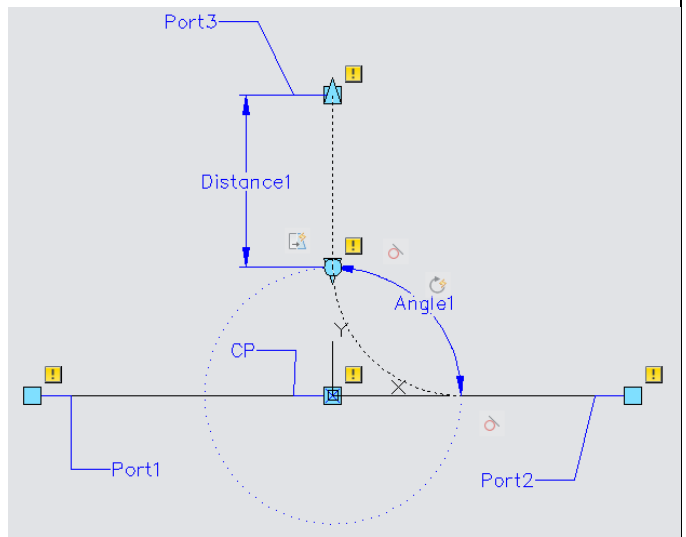

Figure 34 ReducerConc

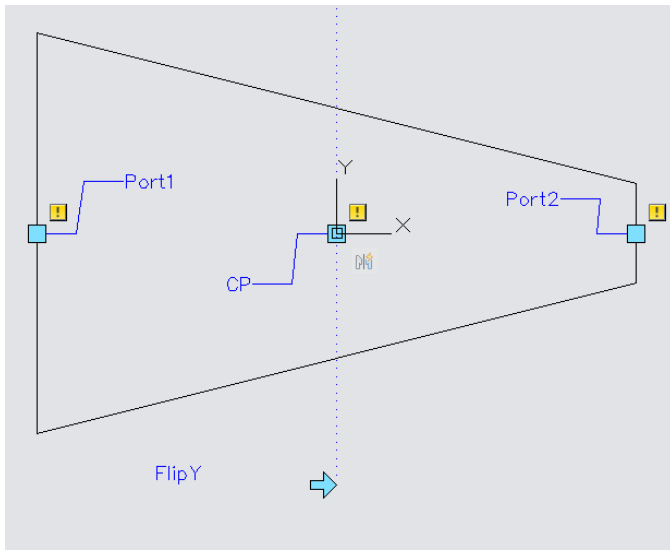

Figure 35 ReducerEcc

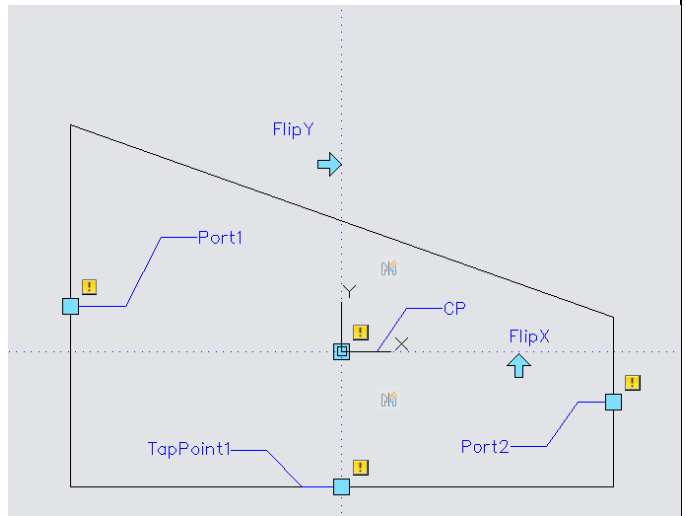

Figure 36 Gasket

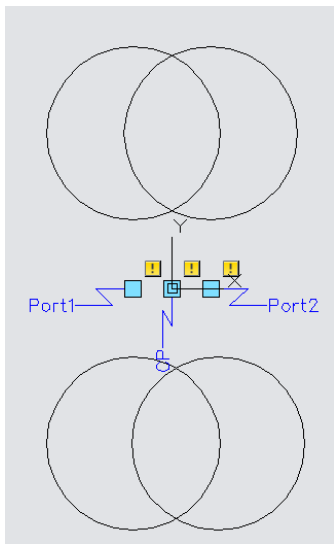

Figure 37 Filter-Strainer

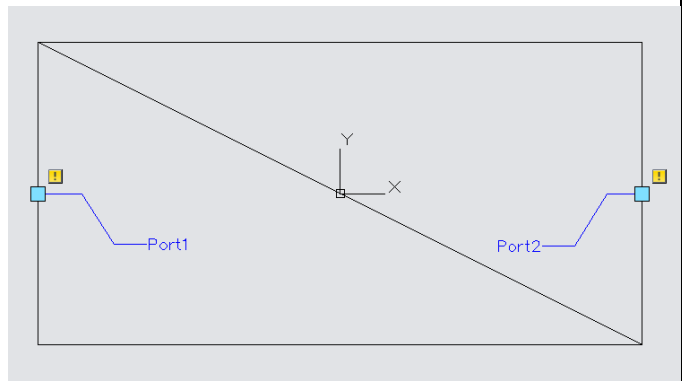

Figure 38 Filter-Angle

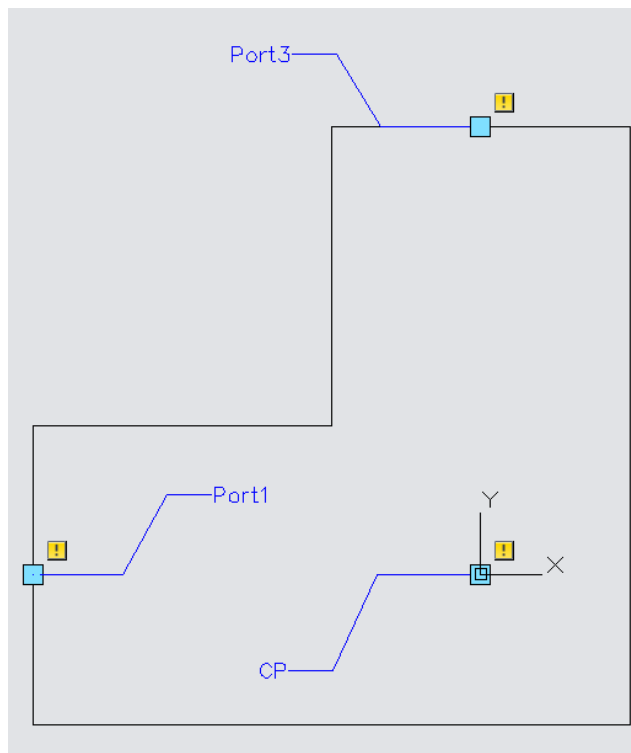

Figure 39 Cross

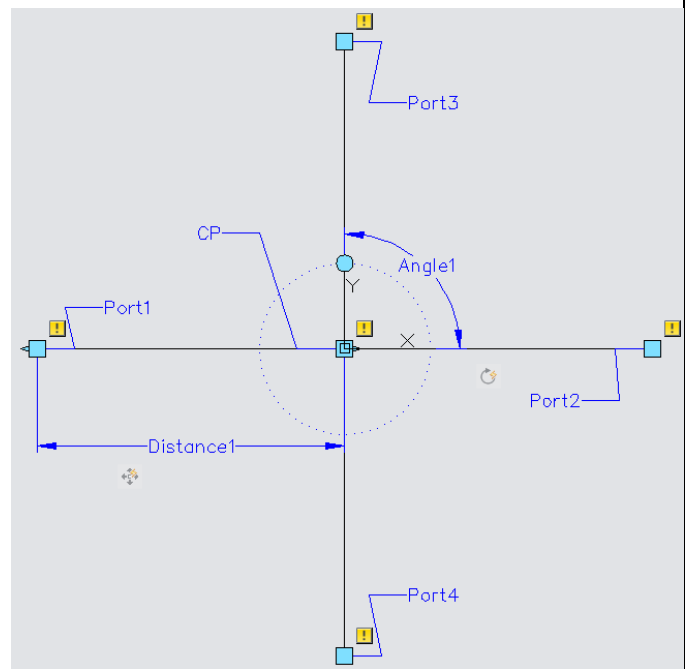

Figure 40 Cap

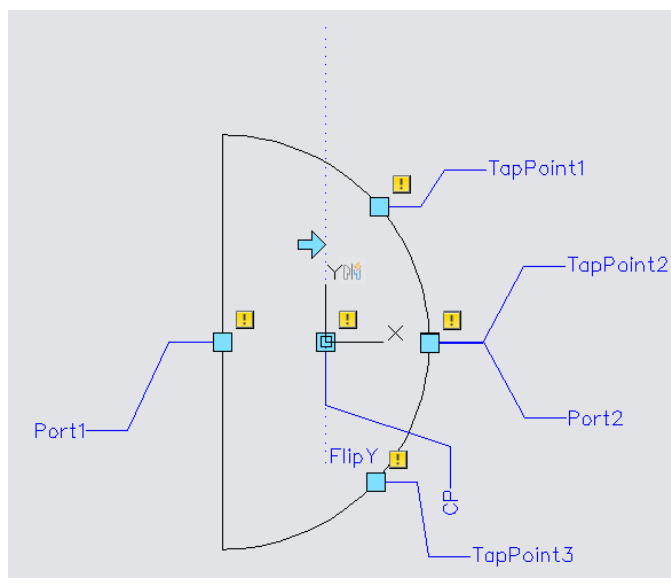

Figure 41 ScrewedCap

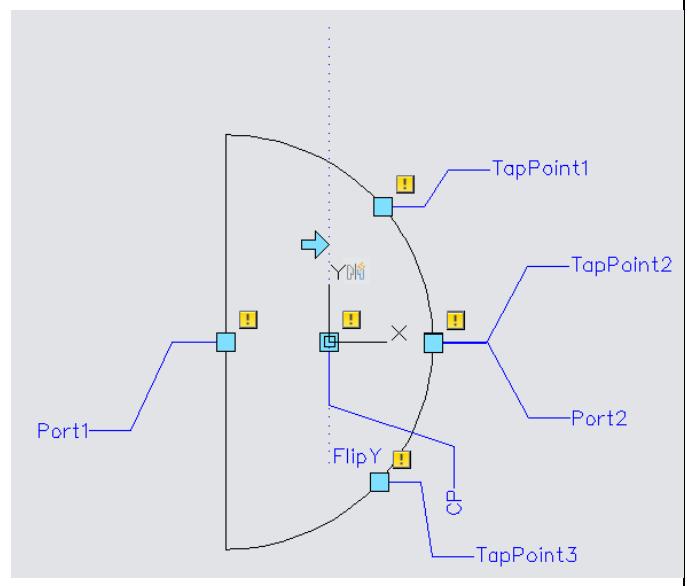

Figure 42 Nipolet

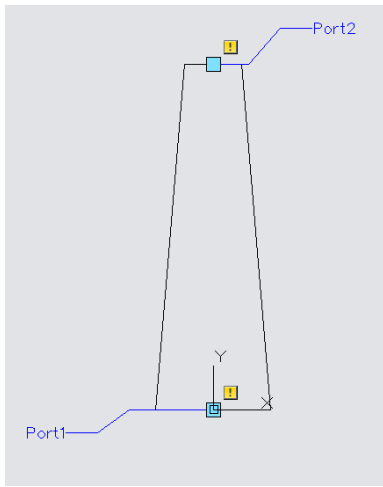

Figure 43 Flange

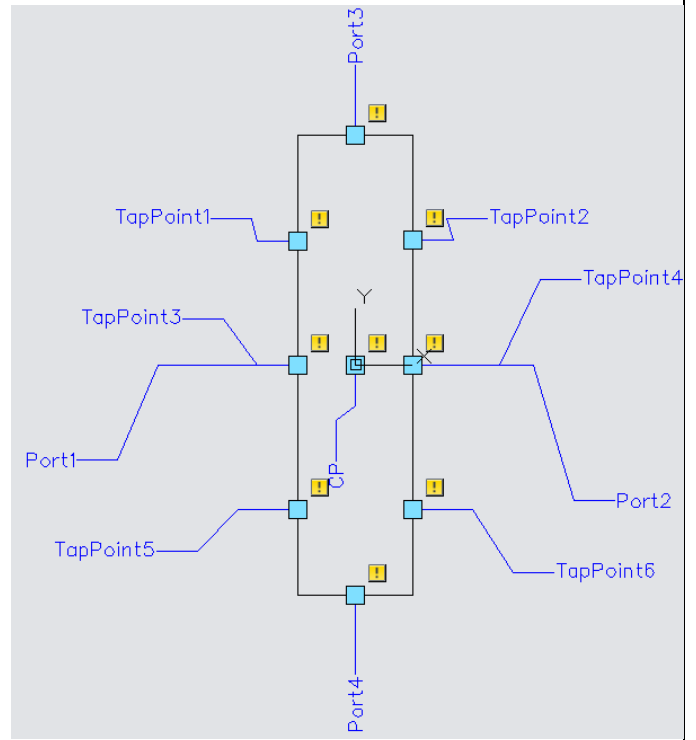

Figure 44 FlangeWN

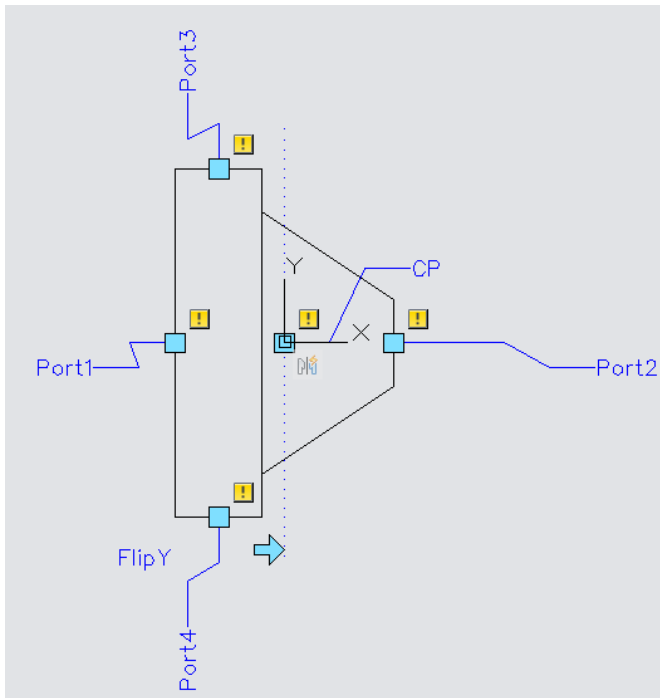

Figure 45 FittingFlange

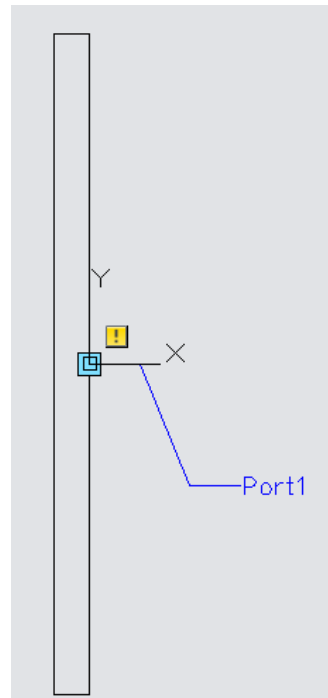

Figure 46 Flange-Lined

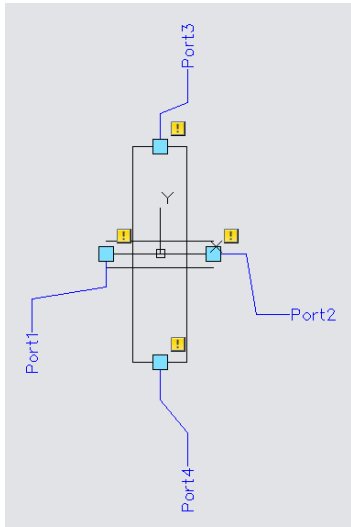

Figure 47 FlangeScrewed

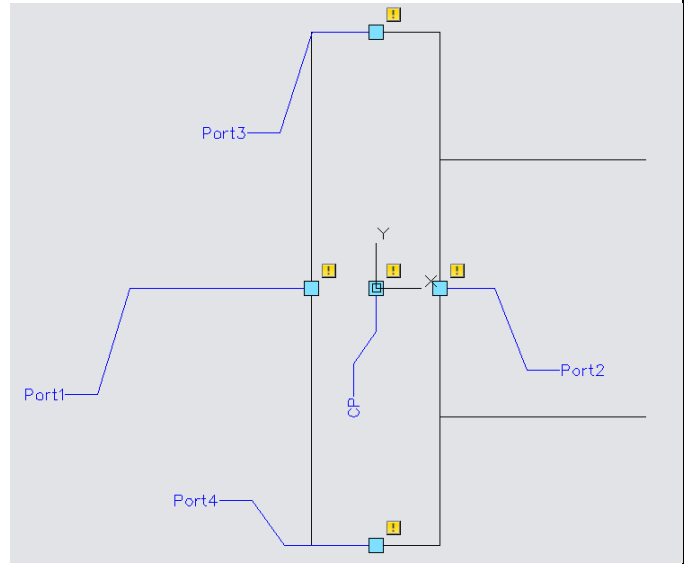

Figure 48 ClampedFlange

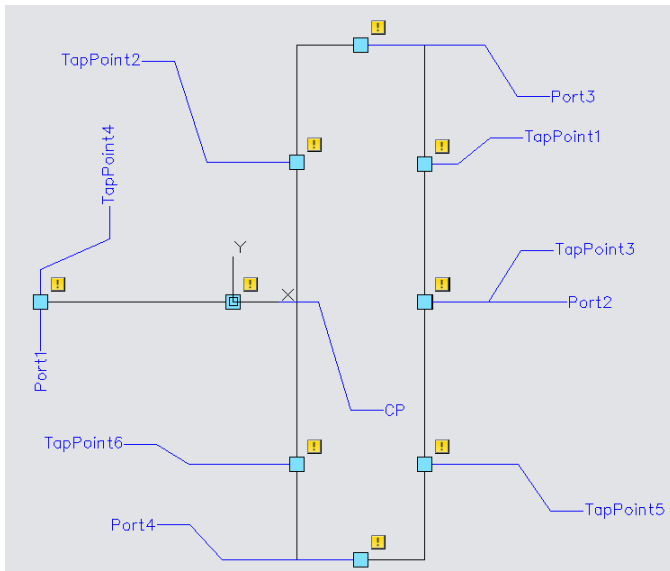

Figure 49 3WayValve

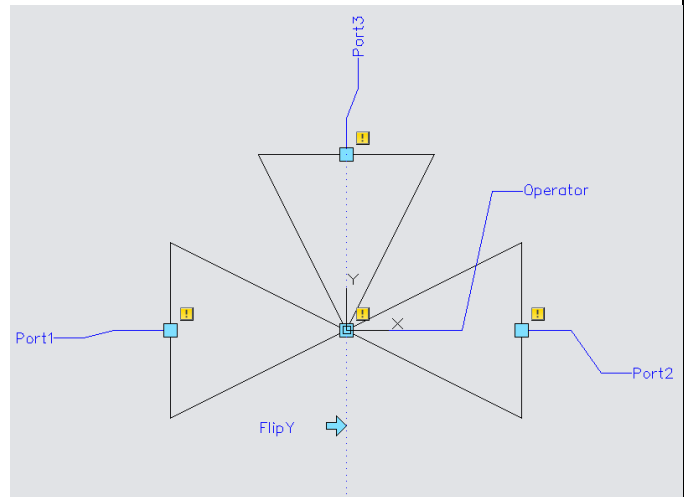

Figure 50 4WayValve

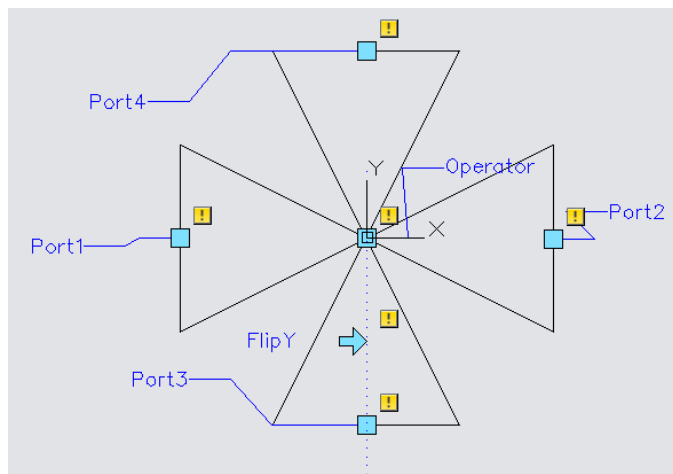

Figure 51 ValveAngle

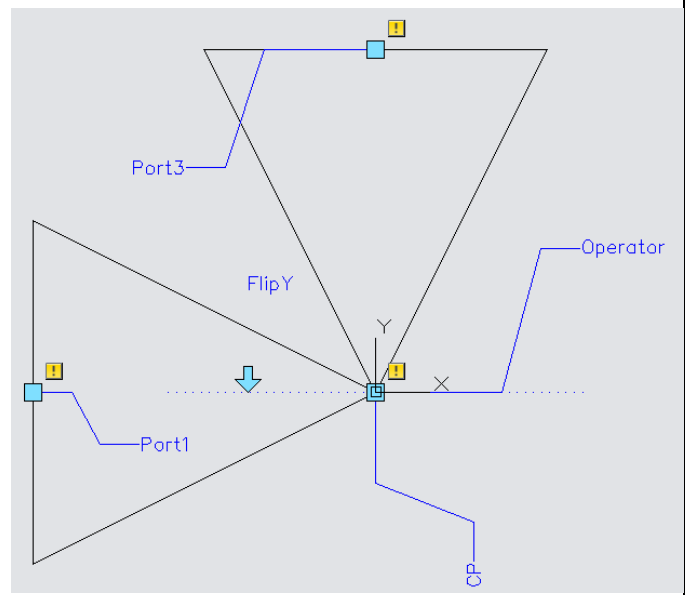

Figure 52 BallValve

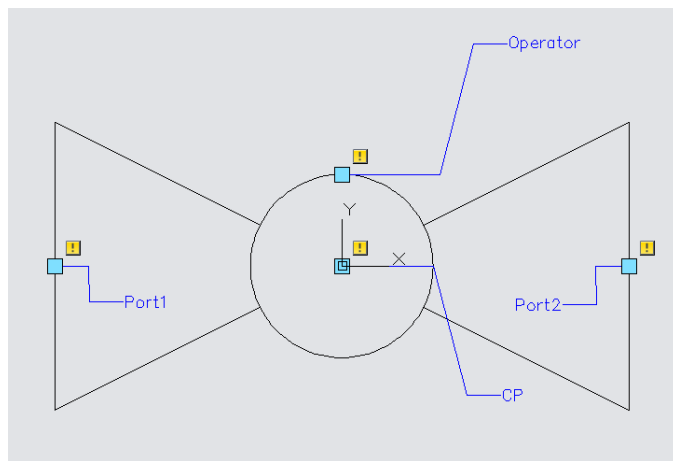

Figure 53 CheckValve-Alt1

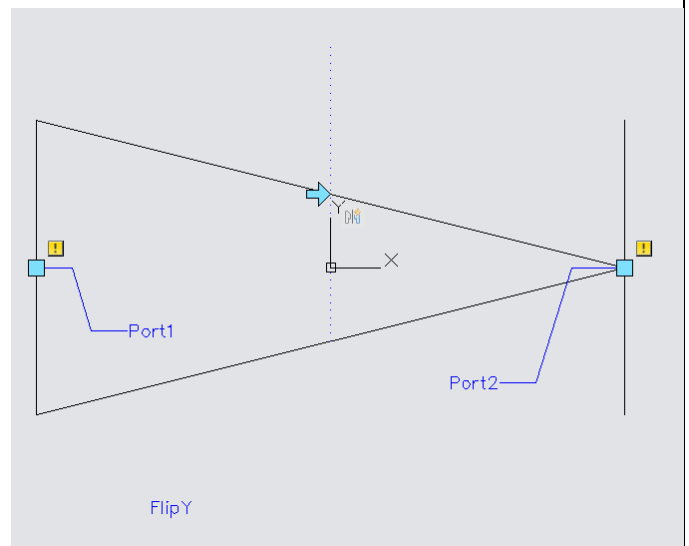

Figure 54 Operator_Hand1

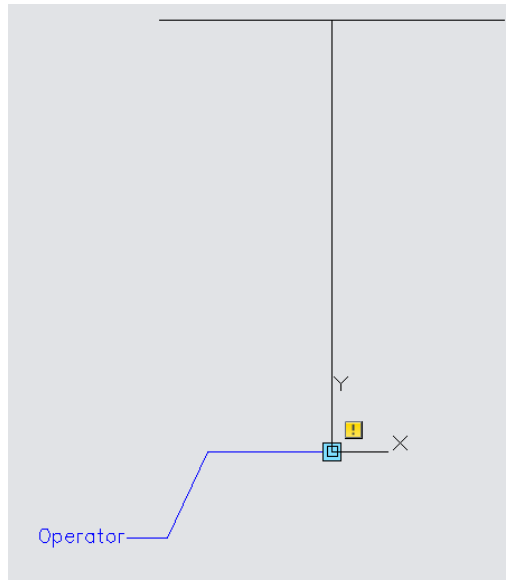
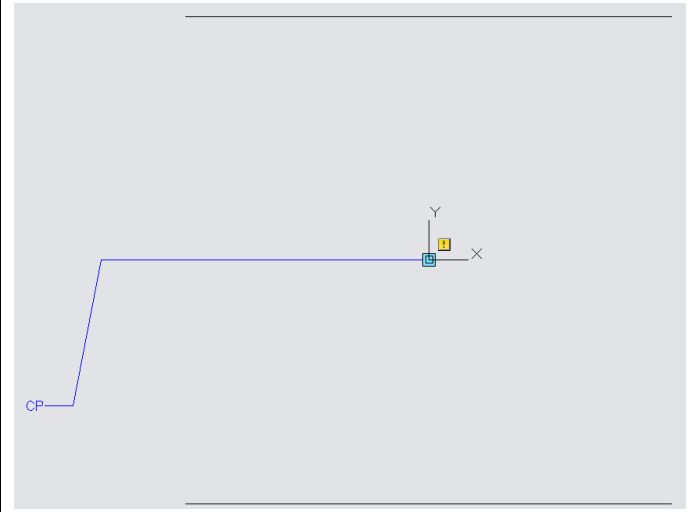

Figure 55 Support



5.3 Default Symbol Types

Along with recognizing which symbol should be used, you need to know which types are available. The type controls what information gets included on the isometric. For example, certain objects like caps get a callout indicating that it closes the end of the pipe line. Any symbol that should receive the closing callout should use the CAP type with whichever symbol key is appropriate. In some scenarios, you will need to test a couple different types in order to get the exact look you need for your isometric. The types below were extracted from the catalogs, so the list may not be comprehensive.

- BEND
- BEND-TEED
- BOLT
- CAP
- COUPLING
- CROSS
- ELBOW
- ELBOW-REDUCING
- ELBOW-TEED
- FILTER
- FLANGE
- FLANGE-BLIND
- GASKET
- INSTRUMENT
- INSTRUMENT-3WAY
- INSTRUMENT-ANGLE
- LAPJOINT-STUBEND
- MISC-COMPONENT
- OLET
- PIPE
- REDUCER-CONCENTRIC
- SUPPORT
- TEE
- TEESIDEOUTLET
- TRAP
- UNION
- VALVE
- VALVE-3WAY
- VALVE-4WAY
- VALVE-ANGLE

5.4 Creating Custom Symbols

One symbol people frequently want to show is a flow meter sometimes shown as the  symbol from the P&IDs. To create the symbol you will need to decide which default symbol to use as a template, save it as a new block, create a reference to the block in our Isoskeyacadblockmap.xml, and apply the new key in a model.

5.4.1 Creating a symbol

Rather than creating new symbols on the fly, the best approach is to use an existing symbol that is similar to the one being created. You should choose a symbol that has the same number of ports and similar behavior. For example, if your symbol is flow dependent, start by using the check valve symbol. Project symbols are stored in the Isometric folder in the drawing called IsoSymbolStyles.dwg. These symbols can be applied to any style in the project.

After opening the IsoSymbolStyles.dwg, enter BEDIT at the command line to launch the block editor. Locate CheckValve-Alt1 and click OK.

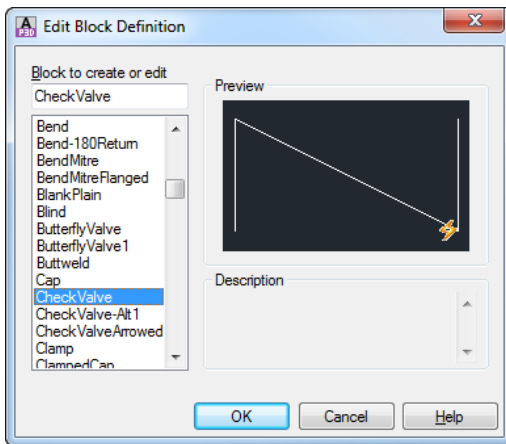

Create a new block called FlowMeter by using Save Block As.

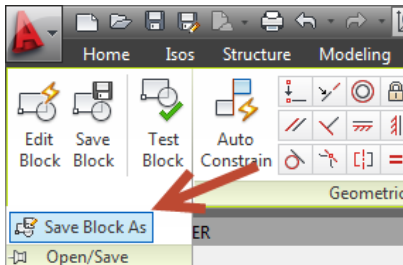

Replace the line work with our boxed M. Also, move the Port1 and Port2 point parameters to the midpoint of your square if needed. The image below uses text height =1, so the box is 1.5 x 1.5 units. Use lines instead of text, since text does not always orient itself correctly inside of blocks.

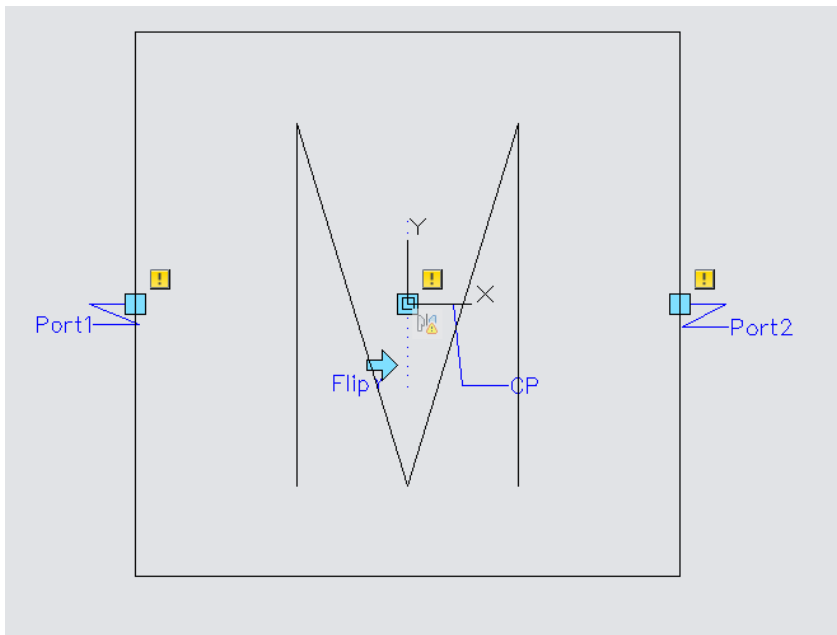

Save and close the FlowMeter block and IsoSymbolStyles.dwg.

5.4.2 Create the symbol key reference

Open IsoSkeyAcadBlockMap.xml in your project's Isometric folder. Scroll down to the section title Instrument symbols, and add this line:

```
<SkeyMap SKEY = "FM???" AcadBlock="FlowMeter"/>
```

This line indicates that when a model component has a symbol key that starts with FM and uses any valid endtype, the FlowMeter block should be inserted in the isometric. If you use an SKEY that's not in this mapping table, isometrics will attempt to find a block with the same name as the SKEY in the isosymbolstyles drawing.

```
<EndTypeMap SKEY = "TC" AcadBlock = "FlareEnd" OnFitting="true"/>
<EndTypeMap SKEY = "BV" AcadBlock = "ButtWeld"/>
<EndTypeMap SKEY = "CL" AcadBlock = "Clamp"/>
<!-- End: Connections -->

<!-- Begin: Instrument symbols -->
<SkeyMap SKEY = "ITFL" AcadBlock = "Instrument-Tee" />
<SkeyMap SKEY = "II???" AcadBlock = "Instrument-Inline"/>
<SkeyMap SKEY = "FM???" AcadBlock="FlowMeter"/>
<!-- End: Instrument symbols -->

<!-- Begin: Misc. symbols -->
<SkeyMap SKEY = "FLOW" AcadBlock = "FlowArrow"/>
```

Save your changes to the IsoSkeyAcadBlockMap.xml

5.5 Assigning Custom Symbols

Below is a ball valve from a model. The Content Iso Symbol Definition is filled out with the SKEY and the TYPE. Notice that there is not a space after the comma separating the two items. Including a space will not allow the correct symbol key to be used. The order, however, does not matter, so you can put the TYPE or the SKEY first. To test the symbol key, fill out the key so it says, "FMFL".

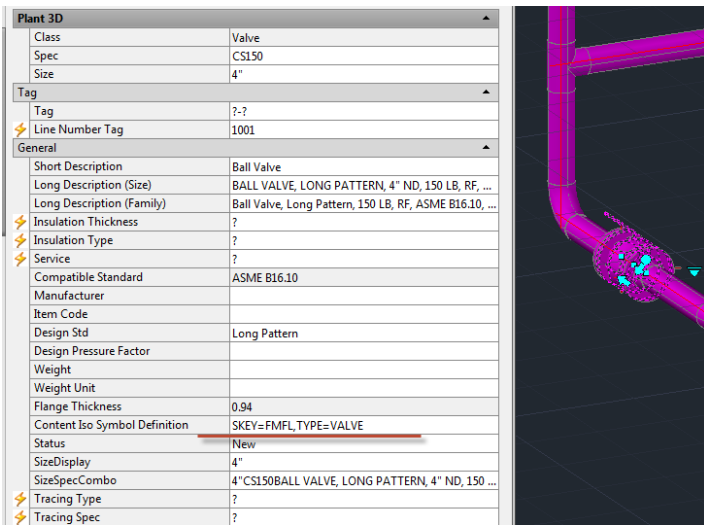

The produced iso has an operator since we tested it on a ball valve. If we were to use a custom flow meter, the operator would not be present.

After creating a symbol key, you should apply it to an item in the model and test it before implementing it in a catalog.

Once you have verified the key is drawn correctly and uses the appropriate type, you may add it to the catalog component on the General Properties tag and the bottom right under Piping Component Properties. Adding it to the catalog will allow the component to come in with the correct isometric symbol. To add our new symbol key to a catalog, you should use the INSTRUMENT type with our FMFL symbol key.

Figure 56 Iso Symbol Type and Skey at bottom right

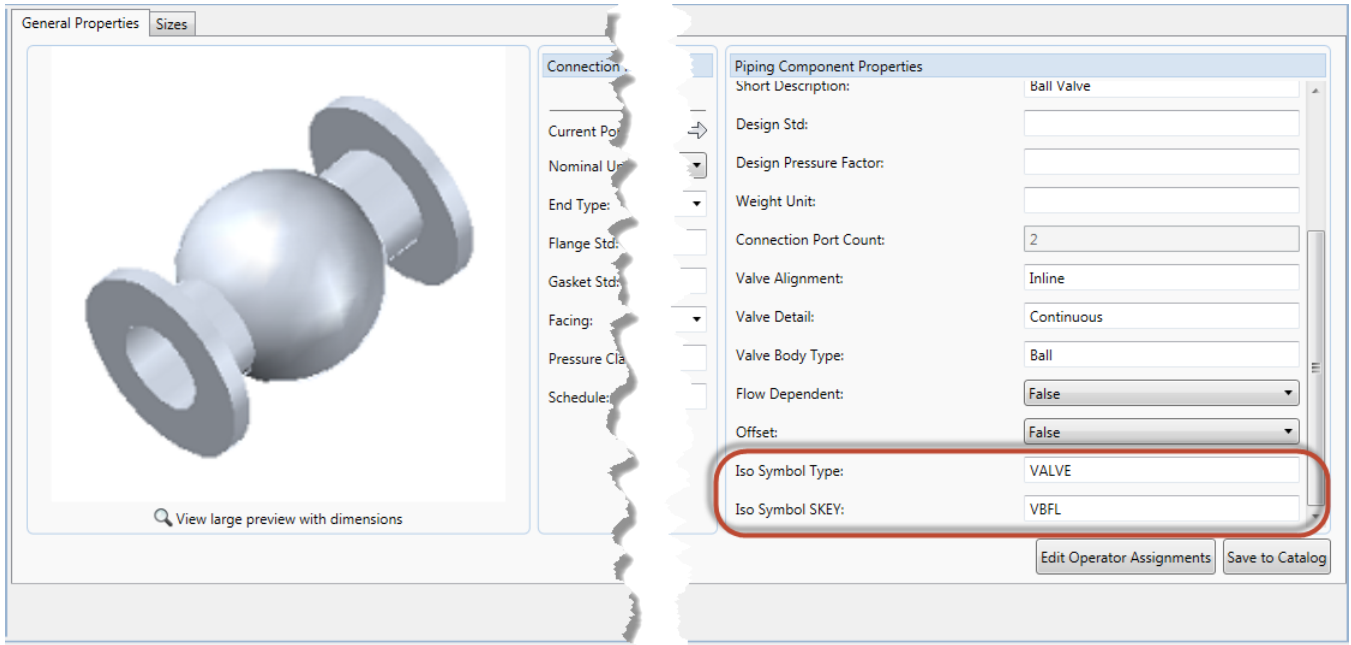

6 Advanced Isoconfig.xml Techniques

6.1 What is the isoconfig.xml

Xml stands for eXtensible Markup Language. Although called, a language, it's better to think of xml as a way of organizing information for developers. Xml is closer to customizable database format than a programming language. For further information on using XML please read: http://www.w3schools.com/xml/xml_what.asp

Because we are not working with web files, understanding html and JavaScript is not a prerequisite for a successful isometric implementation. Information within xml is grouped within tags by including sub-tags, and/or attributes. The contents and types of tags are completely definable by the developer. The xml follows a loose structure dictated here: http://www.w3schools.com/xml/xml_tree.asp. To summarize, xml documents have a namespace declaration in opening and closing brackets, and then a root element which encapsulates the rest of the child elements. In short, xml is organized in a tree hierarchy with elements indicated by brackets. Applying the structure to the isoconfig.xml, our root element is the element IsoconfigDefinition.

Xml definitions:

Tag – a value surrounded in brackets, i.e. <Tag>

Closed Tags – an element (tag) is closed with a slash "/" - <Tag/>. Elements with children are started with an open tag, <Tag> and closed following the children elements with a close tag, </Tag>.

Attributes – A property of a tag residing within its brackets, i.e. <Tag IsLinear="true"/>. The IsLinear value is an attribute that has a true or false value.

Comments – Comments are surrounded with <!-- and closed with !-->

6.1.1 Viewing XML files

Because xml is used so frequently, several applications can be used to view xml files. By default, in Windows, if you open the xml files, it will open read-only in Internet Explorer.

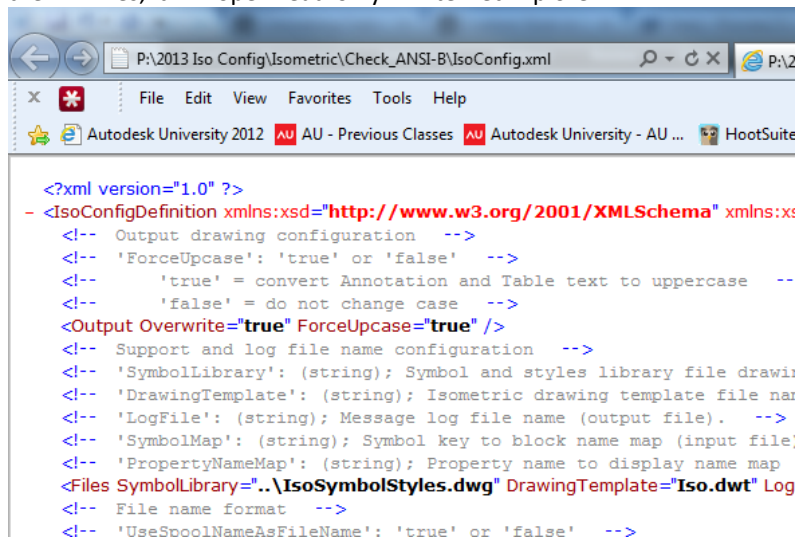

```
<?xml version="1.0" ?>
- <IsoConfigDefinition xmlns:xsd="http://www.w3.org/2001/XMLSchema" xmlns:xsi="http://www.w3.org/2001/XMLSchema-instance" >
  <!-- Output drawing configuration -->
  <!-- 'ForceUppcase': 'true' or 'false' -->
  <!-- 'true' = convert Annotation and Table text to uppercase -->
  <!-- 'false' = do not change case -->
  <Output Overwrite="true" ForceUppcase="true" />
  <!-- Support and log file name configuration -->
  <!-- 'SymbolLibrary': (string); Symbol and styles library file drawi
  <!-- 'DrawingTemplate': (string); Isometric drawing template file nar
  <!-- 'LogFile': (string); Message log file name (output file). -->
  <!-- 'SymbolMap': (string); Symbol key to block name map (input file)
  <!-- 'PropertyNameMap': (string); Property name to display name map
  <Files SymbolLibrary="..\IsoSymbolStyles.dwg" DrawingTemplate="Iso.dwt" Log
  <!-- File name format -->
  <!-- 'UseSpoolNameAsFileName': 'true' or 'false' -->
```

If you right-click, and choose edit, the xml file will open in Notepad.

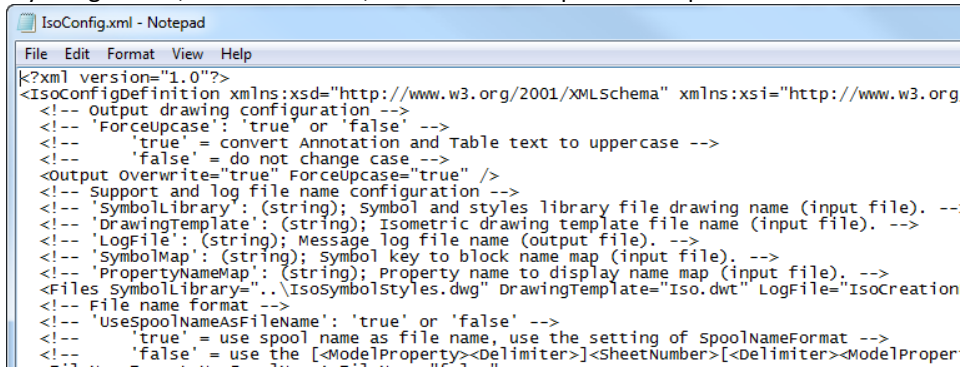

```
<?xml version="1.0"?>
<IsoConfigDefinition xmlns:xsd="http://www.w3.org/2001/XMLSchema" xmlns:xsi="http://www.w3.org
<!-- Output drawing configuration -->
<!-- 'Forceuppercase': 'true' or 'false' -->
<!-- 'true' = convert Annotation and Table text to uppercase -->
<!-- 'false' = do not change case -->
<Output overwrite="true" Forceuppercase="true" />
<!-- Support and log file name configuration -->
<!-- 'SymbolLibrary': (string); Symbol and styles library file drawing name (input file). -->
<!-- 'DrawingTemplate': (string); Isometric drawing template file name (input file). -->
<!-- 'LogFile': (string); Message log file name (output file). -->
<!-- 'SymbolMap': (string); Symbol key to block name map (input file). -->
<!-- 'PropertyNameMap': (string); Property name to display name map (input file). -->
<Files SymbolLibrary="..\IsosymbolStyles.dwg" DrawingTemplate="Iso.dwt" LogFile="IsoCreation
<!-- File name format -->
<!-- 'UsespoolNameAsFileName': 'true' or 'false' -->
<!-- 'true' = use spool name as file name, use the setting of SpoolNameFormat -->
<!-- 'false' = use the [<ModelProperty><Delimiter><SheetNumber>[<Delimiter><ModelProper
```

Because neither of these opens is user-friendly, other applications have been developed to make editing xml files easier.

6.1.2 XML Notepad 2007

Microsoft created an application called XML Notepad 2007. It has some good editing features, like Tree View, and XSL Output (source view).

Figure 57 XML Notepad 2007

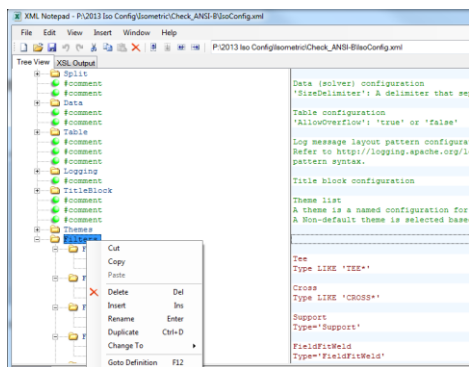

6.1.3 Foxe

Another free editor with great features is Foxe (First Object Xml Editor) http://www.firstobject.com/dn_editor.htm

One of the reasons it is attractive is the ability to customize the display of tree nodes, and the display of the source, the ability to verify the formatting of the xml, and the tools for copying/modifying nodes.

Figure 58 Foxe

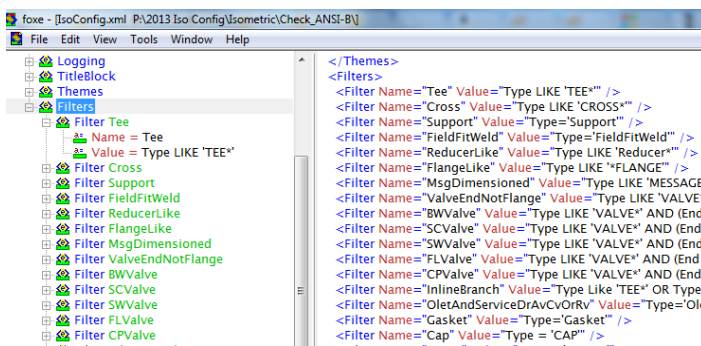

The PDO Team has an article on configuring Foxe to work with Plant 3D:

<http://www.pdoteam.com/2012/08/editing-xml-files/>

Foxe will be used throughout this tutorial for screenshots and customization samples.

6.1.4 Iso Configuration Editor

For those who prefer not to editing xml directly, a specialized isoconfig editor has been written by the PDO Team

<http://www.pdoteam.com/store/iso-configuration-editor/>

Figure 59 Iso Configuration Editor

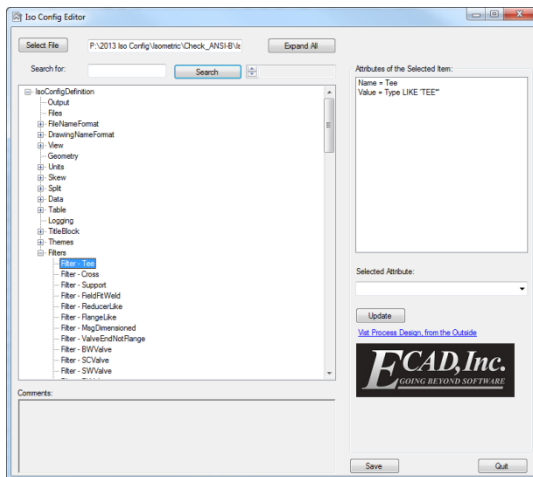

6.2 Iso Config Sections

The isoconfig.xml is structured into different sections that the program uses to organize information about creating an isometric. Some of the sections are not visible or usable through Project Setup, while others are included in the settings dialogs, or title block setup environment. When modifying the isoconfig.xml, you should not be in the project setup dialog. When the project setup dialog is opened or closed, it overwrites any changes that were made outside of Plant. Also, remember to make a backup before you start making significant changes. Sometimes you may make a change that Plant 3D doesn't recognize and you need to be able to revert back to a working copy of the isoconfig.xml.

6.2.1 Sections governed by Plant 3D

The following sections are best modified through the project setup dialog.

6.2.1.1 TitleBlockArea

As mentioned, some settings are controlled through settings accessible within Plant 3D. For example, the draw areas are stored in the isoconfig.xml View > TitleBlockArea > DrawingAreas, but easier to modify through the Title Block Setup.

Figure 60 Draw Areas in the Isoconfig.xml

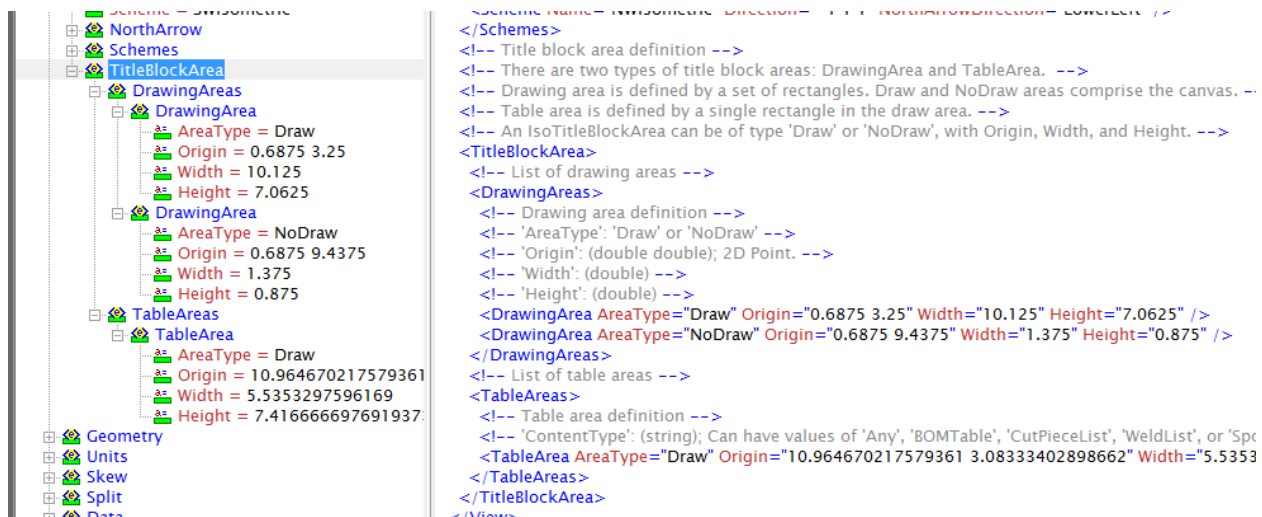
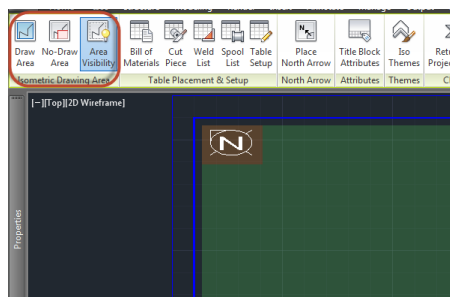

Figure 61 Draw Area Tools



6.2.1.2 Skew

Skew has many settings available in the Project Setup dialog, but even more in the Isoconfig.xml

Figure 62 Skew Settings in IsoConfig.xml

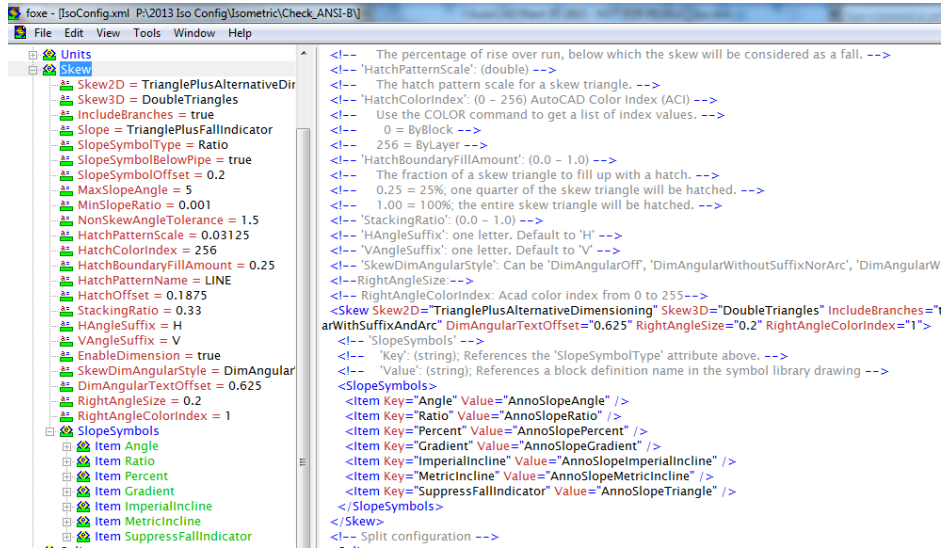
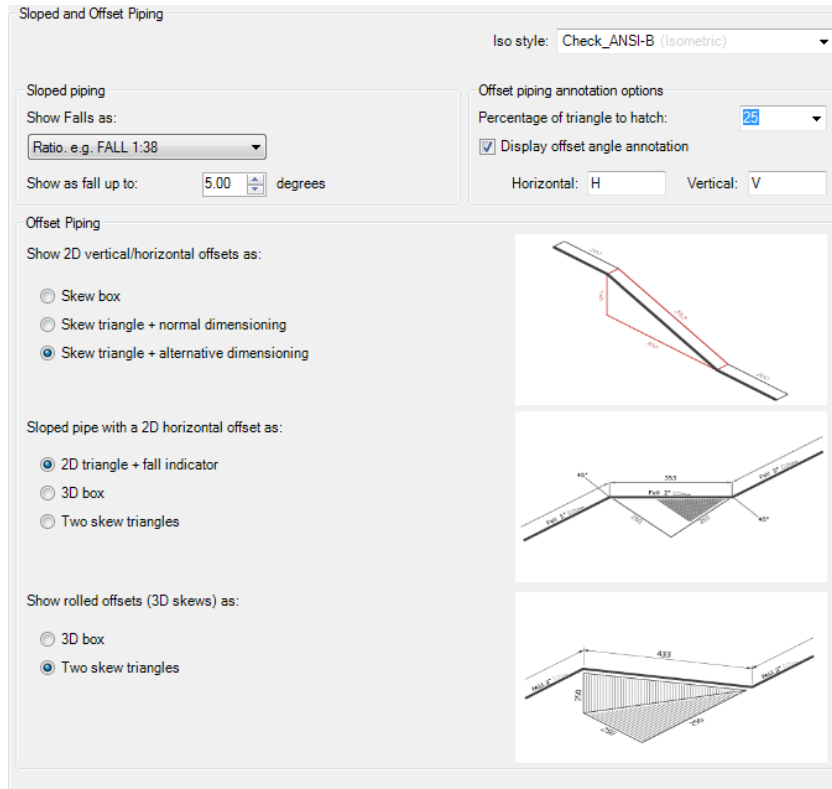

Figure 63 Skew settings in Project Setup



6.2.1.3 TableSchemes

While table schemes are stored in the isoconfig.xml, most of the tools you need to work with them are controlled by the Table Setup dialog.

Figure 64 Available Tables

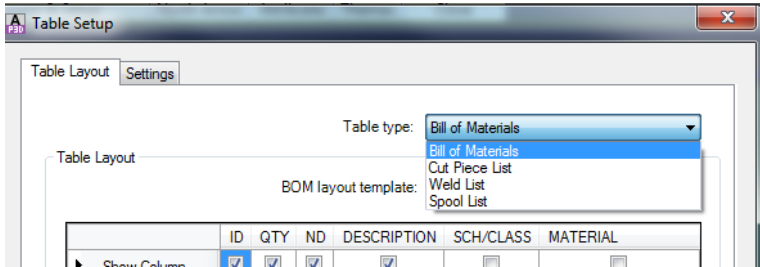

For Bill of Material (BOM), you have three options, Simple BOM, Grouped with Category Title, and Group with Independent Columns.

Figure 65 BOM Types

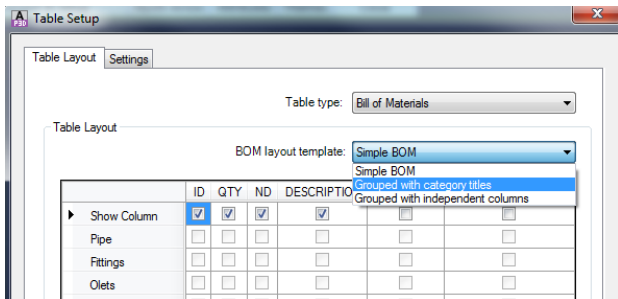

In addition, you can include fabrication and erection tables to break down the BOM further.

Figure 66 Fabrication and Erection Sections

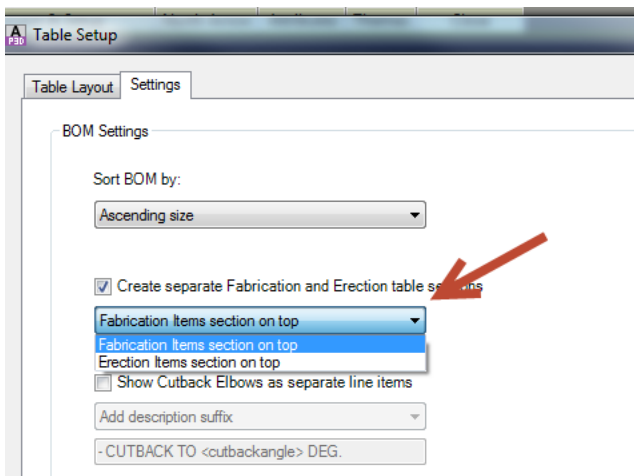

6.2.1.3.1 Simple BOM

The default BOM is a straight listing of all the items on the isometric.

Figure 67 Simple BOM

BILL OF MATERIALS			
ID	QTY	ND	DESCRIPTION
1	3'-6"	3"	PIPE, SEAMLESS, PE, ASME B36.10, ASTM A106 GR B SMLS, SCH 40
2	1'-9"	4"	PIPE, SEAMLESS, PE, ASME B36.10, ASTM A106 GR B SMLS, SCH 40
3	1	4"x3"	REDUCER (CONC), BW, ASME B16.9, ASTM A234 GR WPB SMLS, SCH 40
4	1	3"	FLANGE WN, 150 LB, RF, ASME B16.5, ASTM A234 GR WPB
5	1	4"	FLANGE WN, 150 LB, RF, ASME B16.5, ASTM A234 GR WPB
6	16	5/8"x3 1/2"	BOLT SET, RF, 150 LB, STUD BOLT
7	4	5/8"x3 1/2"	BOLT SET, RF, 150 LB, STUD BOLT
8	1	3"	GASKET, SWG, 1/8" THK, RF, 150 LB, ASME B16.20, CS/PTFE
9	2	4"	GASKET, SWG, 1/8" THK, RF, 150 LB, ASME B16.20, CS/PTFE
10	1	4"	BALL VALVE, LONG PATTERN, 150 LB, RF, ASME B16.10, ASTM A216 GR WPB, HAND LEVER

6.2.1.3.2 BOM Grouped with Category Titles

To have a BOM with items categories, you should use the Group with Category Titles option.

Figure 68 BOM with Category Title

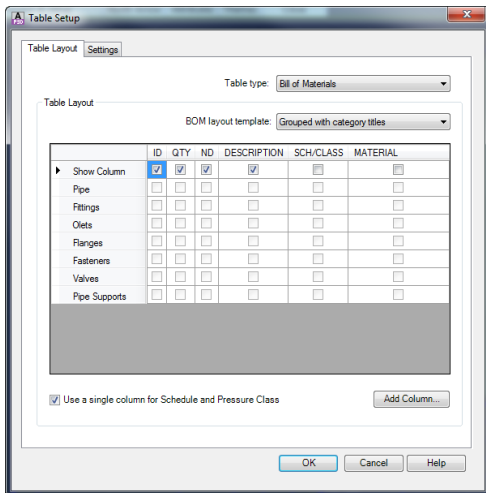

Figure 69 Title Block BOM with Categories

BILL OF MATERIALS			
ID	QTY	ND	DESCRIPTION
PIPE <pipe>			
<ID>	<QTY>	<ND>	<DESCRIPTION>
FITTINGS <fittings>			
<ID>	<QTY>	<ND>	<DESCRIPTION>
OLETS <olets>			
<ID>	<QTY>	<ND>	<DESCRIPTION>
FLANGES <flanges>			
<ID>	<QTY>	<ND>	<DESCRIPTION>
FASTENERS <fasteners>			
<ID>	<QTY>	<ND>	<DESCRIPTION>
VALVES <valves>			
<ID>	<QTY>	<ND>	<DESCRIPTION>
PIPE SUPPORTS <pipe supports>			
<ID>	<QTY>	<ND>	<DESCRIPTION>

When the iso is produced, the items will be categorized appropriately.

Figure 70 BOM with Categories

BILL OF MATERIALS				
ID	QTY	ND	DESCRIPTION	
PIPE				
1	3'-5"	3"	PIPE, SEAMLESS, PE, ASME B36.10, ASTM A106 GR B SMLS, SCH 40	
2	1'-9"	4"	PIPE, SEAMLESS, PE, ASME B36.10, ASTM A106 GR B SMLS, SCH 40	
FITTINGS				
3	1	4"x3"	REDUCER (CONC), BW, ASME B16.9, ASTM A234 GR WPB SMLS, SCH 40	
FLANGES				
4	1	3"	FLANGE WN, 150 LB, RF, ASME B16.5, ASTM A234 GR WPB	
5	1	4"	FLANGE WN, 150 LB, RF, ASME B16.5, ASTM A234 GR WPB	
FASTENERS				
6	16	5/8"x3 1/2"	BOLT SET, RF, 150 LB, STUD BOLT	
7	4	5/8"x3 1/2"	BOLT SET, RF, 150 LB, STUD BOLT	
8	1	3"	GASKET, SWG, 1/8" THK, RF, 150 LB, ASME B16.20, CS/PTFE	
9	2	4"	GASKET, SWG, 1/8" THK, RF, 150 LB, ASME B16.20, CS/PTFE	
VALVES				
10	1	4"	BALL VALVE, LONG PATTERN, 150 LB, RF, ASME B16.10, ASTM A216 GR WPB, HAND LEVER	

6.2.1.3.3 BOM with Independent Columns

Setting up BOM with independent columns will allow you to break down your BOM into the categories, and include additional columns per category. For example, if you want to show the Item Code (Part Number) field only for valves, you can add the Item Code column.

Figure 71 Independent Columns

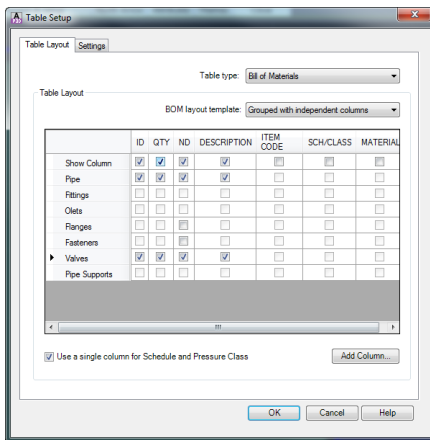

Figure 72 Adding the Item Code Column

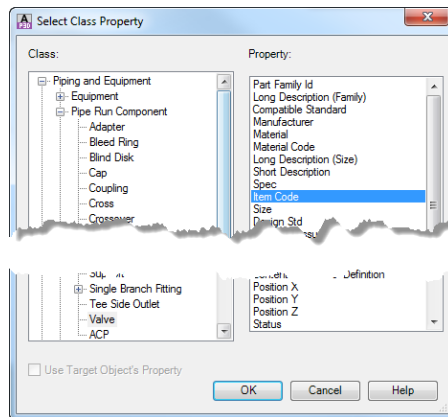
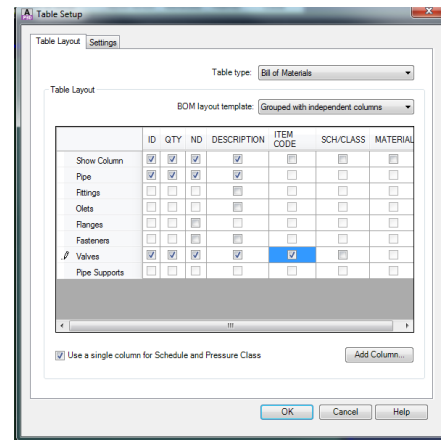

Figure 73 Including Item Code for Valves only



After making your changes to the table setup, your bill of material should include the valve category with an Item Code column.

Figure 74 BOM Table with Valve Category and Item Code

BILL OF MATERIALS				
PIPE <pipe>				
ID	QTY	ND	DESCRIPTION	
<ID>	<QTY>	<ND>	<DESCRIPTION>	
FITTINGS <fittings>				
ID	QTY	ND	DESCRIPTION	
<ID>	<QTY>	<ND>	<DESCRIPTION>	
OLETS <olets>				
ID	QTY	ND	DESCRIPTION	
<ID>	<QTY>	<ND>	<DESCRIPTION>	
FLANGES <flanges>				
ID	QTY	ND	DESCRIPTION	
<ID>	<QTY>	<ND>	<DESCRIPTION>	
FASTENERS <fasteners>				
ID	QTY	ND	DESCRIPTION	
<ID>	<QTY>	<ND>	<DESCRIPTION>	
VALVES <valves>				
ID	QTY	ND	DESCRIPTION	ITEM CODE
<ID>	<QTY>	<ND>	<DESCRIPTION>	<ITEM CODE>
PIPE SUPPORTS <pipe supports>				
ID	QTY	ND	DESCRIPTION	
<ID>	<QTY>	<ND>	<DESCRIPTION>	

Figure 75 Produced Iso with Item Code

7	4	5/8 X 3 1/2"	BOLT SET, RF, 150 LB, STUD BOLT	
8	1	3"	BASKET, SWG, 1/8" THK, RF, 150 LB, ASME B16.20, CS/P1FE	
9	2	4"	BASKET, SWG, 1/8" THK, RF, 150 LB, ASME B16.20, CS/P1FE	
VALVES				
ID	QTY	ND	DESCRIPTION	ITEM CODE
10	1	4"	BALL VALVE, LONG PATTERN, 150 LB, RF, ASME B16.10, ASTM A216 GR WPB, HAND LEVER	BA101

6.2.1.3.4 All of these settings correspond to the TableSchemes section in the isoconfig.xml. In the BOM TableScheme, notice that there are templates defined which are Simple, SemiComplex, and Complex. These templates are the options mentioned above.

```

<TableScheme TableType="BOM" Name="BOM" TemplateName="SemiComplex" TableLayout="Default" TitleVisible="true" HeaderVisible="true" InternalSpacing="0.3937" Grouping="None" ColumnMappings="ID, QTY, ND, DESCRIPTION" Templates="Simple, SemiComplex, Complex" LayoutOption="Complex" ColumnSchemes="ID, QTY, ND, DESCRIPTION, ITEM CODE" />

```

6.2.1.4 Title block Attributes

The title block attribute mappings are stored in the isoconfig.xml, in conjunction with another file, iso.atr. Between these two files, you can heavily customize what is available to place in your drawing. The mappings are created through Title Block setup, in Project Setup. Prior to AutoCAD Plant 3D 2013, you had to create the mappings by hand, since they wouldn't save correctly, but that has been fixed.

Figure 76 Iso Title Block Attributes

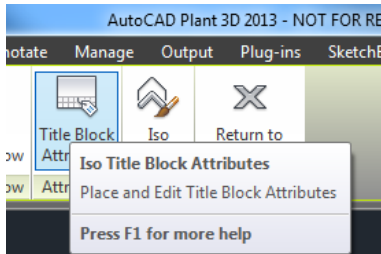

Attributes for project properties, drawing properties and LDT properties get related through the iso.atr file. Per the screen shot below, Attribute1 is mapped to the P3dLineGroup class, and the Service property. Then in the isoconfig.xml TitleBlock section, an Attribute is listed with a Key of Attribute1 (from iso.atr) and then the Tag given is the tag that belongs to the AutoCAD block attribute.

Figure 77 Attribute Mapping

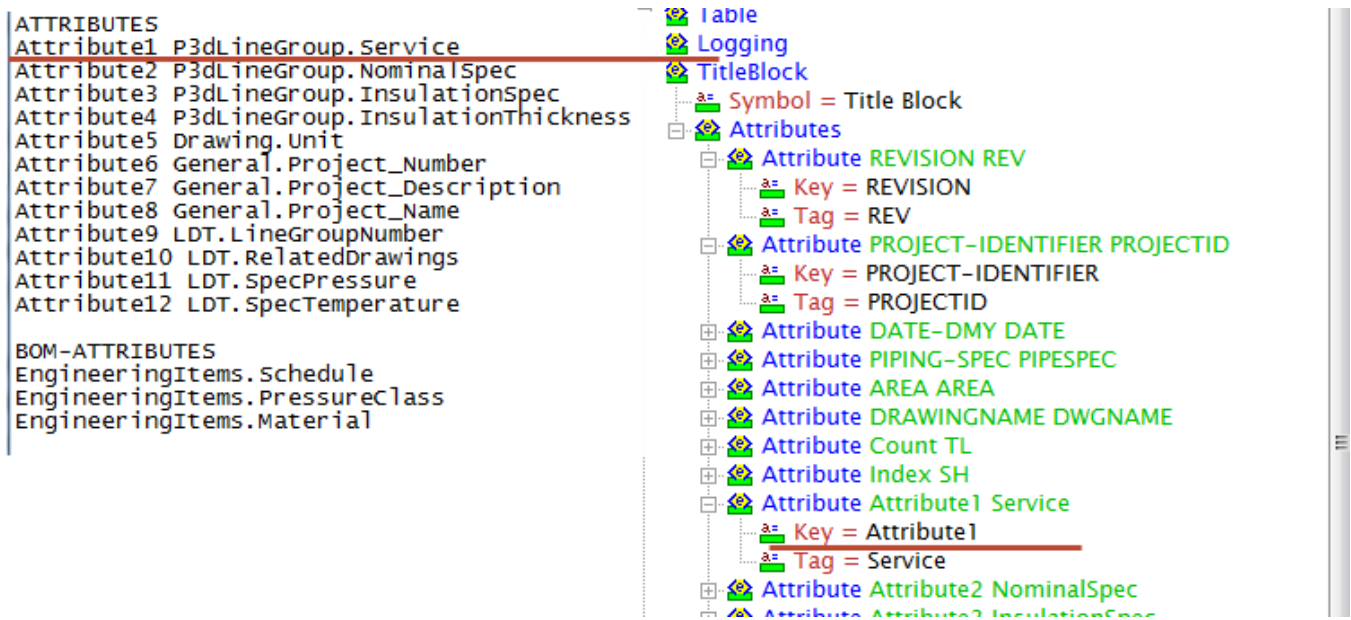

6.2.2 Core Internal Sections

6.2.2.1 Split

The split section controls how the isometric engine will break up the model into drawings.

Figure 78 Splitting Isometrics

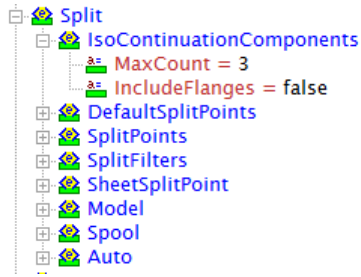

6.2.2.1.1 IsoContinuationComponents

The IsoContinuationComponents section controls how many components are displayed in the continuation message (MaxCount), and whether flanges are included in that count, IncludeFlanges.

6.2.2.1.2 DefaultSplitPoints

The DefaultSplitPoints establish a priority for splitting, as well as the components allowed for splitting. An un-customized list includes split points using filters FlangeLike, WeldFieldItem, Weld, and AnyItem. With these options set, the isometrics can break at flanges, welds or any component it deems necessary. You may add split points to the list, but the default splitpoints cannot be moved or re-arranged.

Figure 79 DefaultSplitPoints

```
weld or other end connection that can be p
be added to this list, but removing items f
<DefaultSplitPoints>
  <SplitPoint Filter="FlangeLike" />
  <SplitPoint Filter="WeldFieldItem" />
  <SplitPoint Filter="Weld" />
  <SplitPoint Filter="AnyItem" />
</DefaultSplitPoints>
<!-- SplitPoints defines user preferred conn
weld or other end connection that can be r
```

6.2.2.1.3 SplitPoints

Similar to DefaultSplitPoints this section specifies component filters for breaking isometrics. However, this list is completely customizable by the user.

6.2.2.1.4 SplitFilters

Defines filter strings used by the program.

6.2.2.1.5 SheetSplitPoint

The SheetSplitPoint section controls what happens to connector components when the sheets are split (if Change is set to true). For example, when a sheet splits at a shop weld, it will change to the value defined in the <Connector> section which can be a field weld or a field fit weld. 'Connector' is a re-use of the Connector defined in <Spool> section, which defines the connector that will replace the shop weld as the new sheet split point.

6.2.2.1.6 Model

The model section controls how to split isometrics with regard to model items. For example, you may want to split isos at spec changes or other property changes. For the Model section, you can set ModelSplitMethod to either PropertyChange or ModelBreakPoint. If you specify PropertyChange, choose your property based on the [model properties](#) or mapped properties. You may also specify a filter instead of a property.

Figure 80 Model Splitting

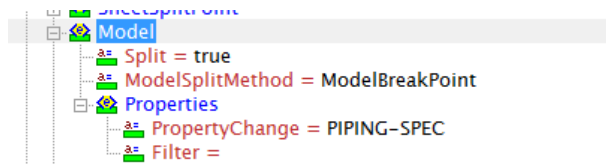

6.2.2.1.7 Spool

The spool section contains settings from the Project Setup dialog, like the size limits, and the split method. Currently, you cannot assign spool names in the model and have them propagate through to the isometric file name, due to a bug, but that should be resolved quickly.

Spool splitting controls how spools are numbered, not just if they are split into spool drawings. The spool splitting can be at a given component type, like flange, but there also can be a maximum size, weight, or direction changes. Maxdirection changes includes olets as direction changes, so if you are seeing spools split too often, you might change the maxdirectionchanges to 0.

6.2.2.1.8 Auto

The Auto section defines what symbol is used for the split mark, whether to split into spool drawings (SpoolSplit), whether the spools should be identified in the isometrics (IdentifySpools), whether drawing congestion should cause splits (SplitOnCongestion), and the level of congestion allowed (CongestionLevel).

6.2.2.2 Data – Controlling Material, Weld, Spool, and Cut List Content

The Data section is responsible for handling how the lists for materials welds, pipes, and spools are handled. Within the Data section there are two nodes, PipeConnectionToConditionMap and Aggregated lists, and an attribute, the SizeDelimiter.

Figure 81 Data Section

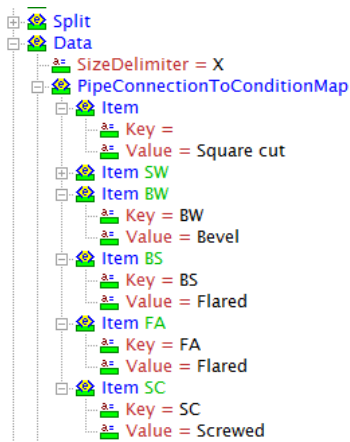
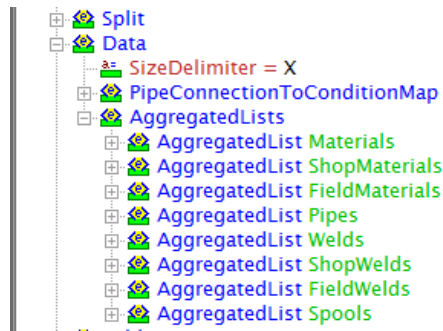

Figure 82 Aggregated Lists



6.2.2.2.1 Size Delimiter

The size delimiter is used to separate main by reduction sizes in the Size column of the iso BOM. For example, entering “ X ” will yield 4” X 3” instead of the default 4”x3”. Despite attempts at table formatting, and using lowercase values here, currently, the isometric will always generate an upper-case size value.

Figure 83 Modified Size Delimiter

BILL OF MATERIALS			
ID	QTY	ND	DESCRIPTION
1	3'-5"	3"	PIPE, SEAMLESS, PE, ASME B36.10 SMLS, SCH 40
2	2'-10"	4"	PIPE, SEAMLESS, PE, ASME B36.10 SMLS, SCH 40
3	1	4" X 3"	REDUCER (CONC), BW, ASME B16. SMLS, SCH 40
			FLANGE WN, 150 LB, PE, ASME B

6.2.2.2.2 End Preparation Mapping

The Connection to connection map designates what types of pipe end preparations are applied to different end types from the mode. If you switch the value for the butt weld connection from Bevel to BVL the Cut Piece list changes.

Figure 84 BW Condition Map

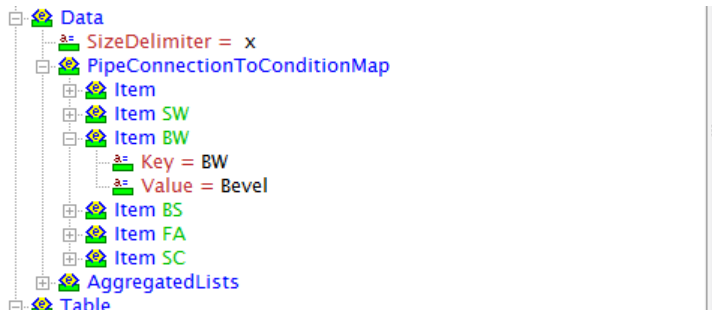

Figure 85 Cut Piece with BVL callout

CUT PIECE LIST					
ID	LENGTH	ND	END1	END2	
1	3'-4 13/16"	3"	BVL	BVL	
2	2'-9 1/4"	4"	BVL	BVL	

PROJECT NAME:

More crucial to the isometric configuration is the Aggregated Lists section. Through the Aggregated Lists section, the contents of the Bill of materials, Cut List, Weld List, and Spool List are controlled. Expanding the Materials AggregatedList gives more insight into the format of these sections.

Figure 86 Materials Aggregated List

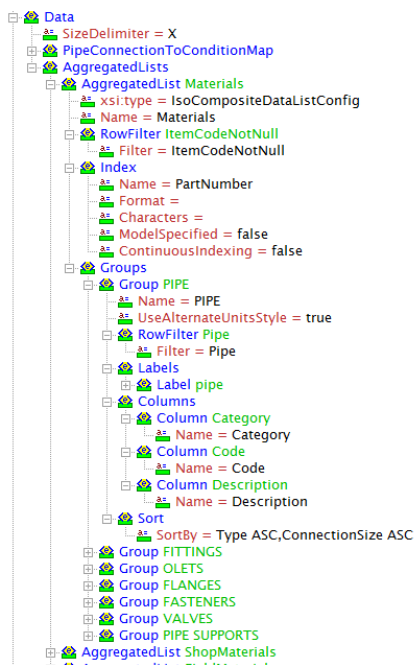

The main nodes under the Aggregated list is the RowFilter, Index, and Groups. The filter for the Materials list is ItemCodeNotNull, meaning that the items listed in the BOM will all have an Item-code property. The item code property comes from the generated pcf, which will also use the Item Code property in the model, if available.

6.2.2.2.3 BOM Indexing – Generic Material List

The Index node refers to which property is to be used for unique identification. Here are the comments from the developer.

Name – An attribute of this name (for example PartNumber) will be added to each isometric component. Then, annotations schemes can use the name specified in their Fields property.

For example, in the Default theme, the PartNumber Component scheme refers to the PartNumber property in the Fields attribute.

Format (optional) – The format of the index, a prefix and suffix may be

specified.

For an example, in the Continuation/Connection Piping theme, locate the EndConnectionScheme. Note that the scheme uses a Format attribute, and the supplies properties via the Fields attribute.

Characters (optional) – string of available characters to use for the index. You can supply your own list of characters to use.

ModelSpecified – Indicates whether or not to use the index from the piping model instead of auto-generation (default is false).

ContinuousIndexing – When continuing onto another sheet, should the numbers continue from the previous sheet or start over at 1 (default is false).

6.2.2.2.4 Groups

The groups section controls how elements in the list get organized. This section may not be available for all types of table content. This section is used in conjunction with the table in the drawing template to locate where items should populate the final table. Some users modify the RowFilter specified by the group to change which content falls into different categories. For example, by modifying the BOMFitting and Pipe filters (or creating similar ones based on the existing filters), you can have nipples grouped with pipe instead of fittings.

6.2.2.3 Table

While the data section controls what items appear in our lists, the Table section control how and where the items appear. The Table section has five parts, TableLayouts, TableTypes, TableSchemes, DataLinks, and OverflowSheetLabelConfig.

The TableLayout section corresponds to table styles defined in our iso template.

The TableType details out specific tables that are used in the isometric. This links the TableScheme with the appropriate table title, and contains general properties like Name, TableSectionType (All, ShopItems, or FieldItems), the scheme to be used, and whether the table is enabled

Tableschemes structure how the content is displayed. However, the table scheme is best modified through the title block editor's Table Setup command.

Figure 87 Table Setup

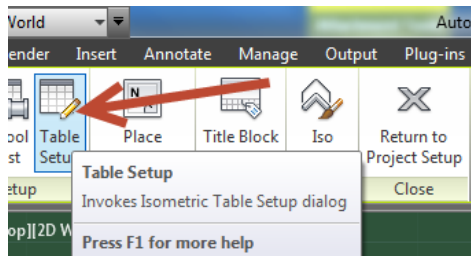

The Datalinks section is a mapping of a table name, ie AllMaterials to an AggregatedList (from the Data section) ie Materials.

The last section relating to tables is the OverflowSheetLabelConfig. This section provides some minor features relating to the overflow sheet like being able to specify a prefix or suffix, AutoLabelOption (Number or Alphabet), the separator to use, along with the number of digits and starting numerical value for the drawing number.

Figure 88 OverflowSheetLabelConfig

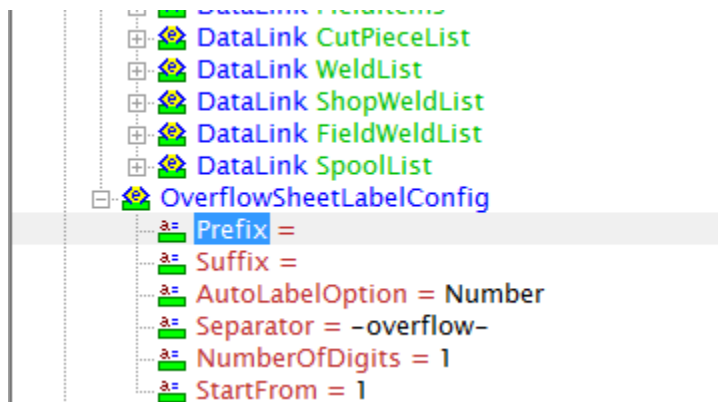

6.2.2.4 Titleblock

The TitleBlock section contains two features, first is the name of the block that will be the title block (under Symbol).

The Attributes section is a map of the attributes referenced in the Iso.atr file and pcf with the attributes located in the isometric template title block. The key is the name of the value in the pcf or iso.atr, and the Tag is the attribute tag within the title block.

Figure 89 TitleBlock Section

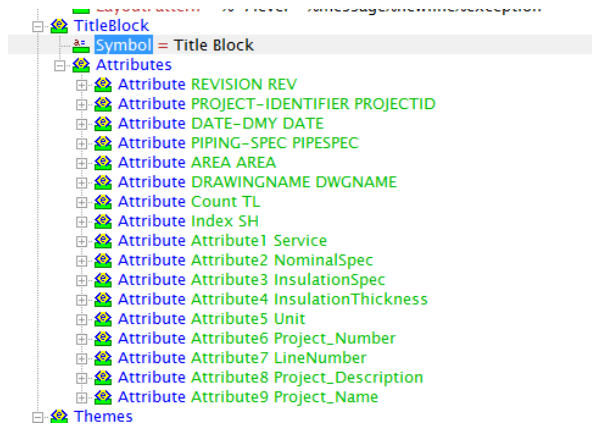

6.2.2.5 Filters

Filters are a structure way of selecting items based on their model properties. The programming equivalent of a filter would be a database query. Filters consist of two parts, the name and the Value. To understand filters, you should read through a couple of them.

The most important note is that the type referenced here is not the class type that displays in the properties palette, but the Iso Content Symbol Definition type.

A simple filter is the Tee. The value for the Tee filter is Type LIKE 'TEE*'. Any of the sections above that reference the Tee filter will get any item whose type starts with tee as the wildcard (*) will allow any other characters after the word TEE. Included in the selection would be TEE, TEE-SET-ON, and TEE-STUB.

If you add a new theme, you may need to define a new filter to determine what is affected by your new theme. Or, you may want to copy an existing filter and change it to modify the behavior of an existing theme. If you change the TEE filter here, the definitions above will all be affected by your change. You may want to add a new filter that's a copy of the Tee filter if you just want to make a change to one place that refers to it.

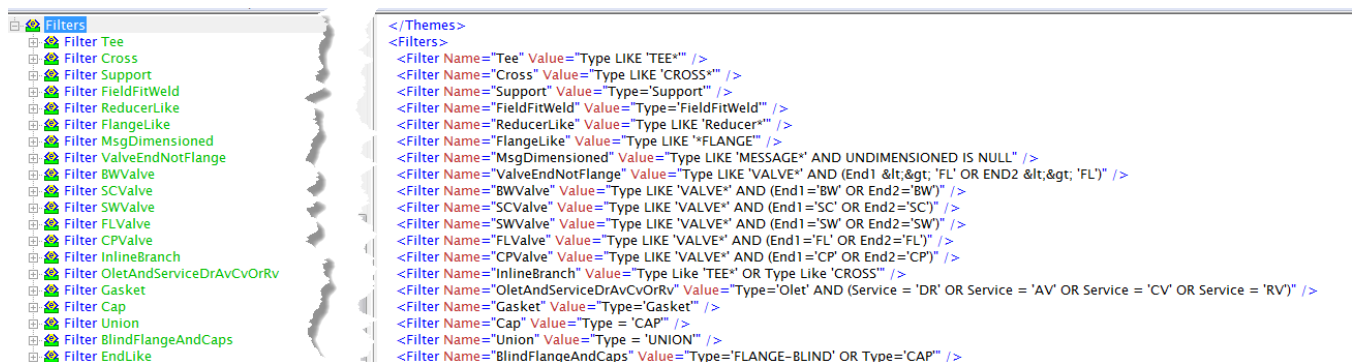

Figure 90 Filters

Refer to <http://msdn.microsoft.com/en-us/library/system.data.datacolumn.expression.aspx> for expression syntax (DataColumn Expressions).

A slightly more complicated filter is a threaded valve (Filter Name = "SCValve"). This particular filter selects any item that uses the VALVE type, and also has either End1 or End2 as SC (screwed). You may create your own filters to modify BOM selections, AnnotationScheme or any other place a filter is used. You should leave the original filter intact (in case you have to revert your changes), and create a new one with a similar name. Using Your XML editor, you can copy a filter node, choose Paste Below, and then rename the pasted filter.

6.3 Display Settings

AutoCAD isometrics provides several options for placing and aligning text and dimensions. This section will document the options available along with screen shots to provide a reference for your drawing customization. Annotation and dimensioning is handled per theme, so you should look through the existing themes to see how it handles the customization.

6.3.1 Dimensions

The Default theme controls most of the dimensioning that appears on the isometric. Most of these options are available in project setup. The Default theme is used generally, and then named themes will apply as overrides to the Default theme as appropriate.

Figure 91 Project Setup Default Dimensions

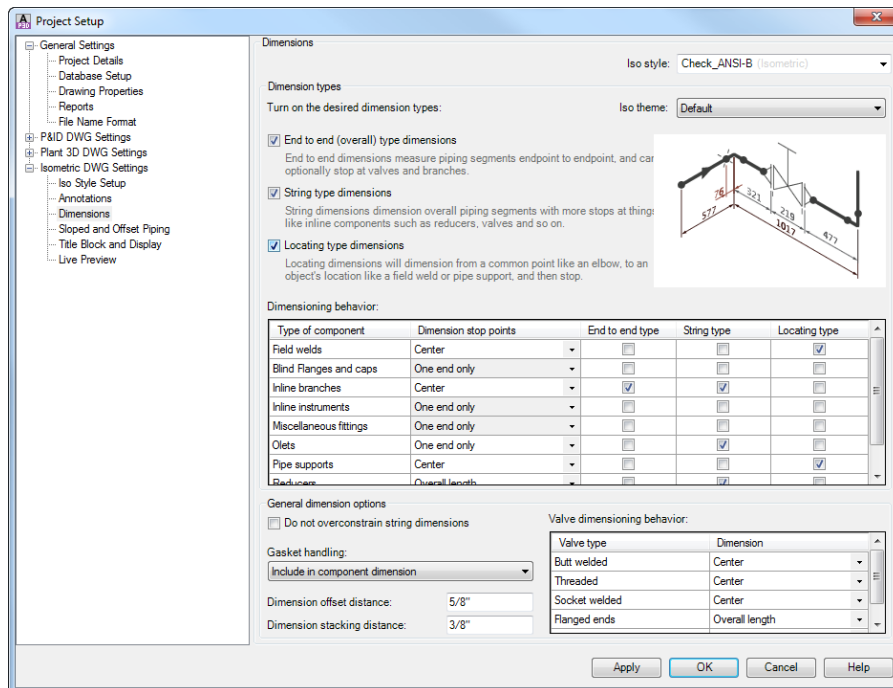
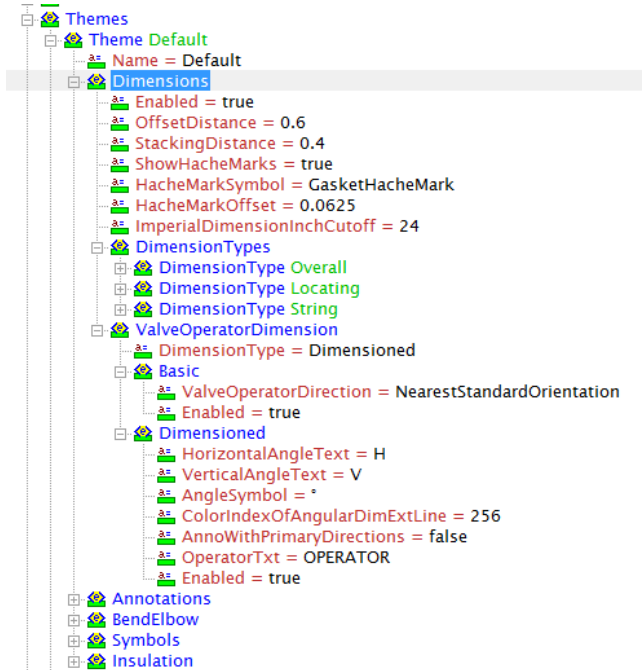

Figure 92 Default Theme Dimensions



6.3.2 Annotations

Theme annotations are probably one of the most flexible, frequently-used options not available in the project setup dialog. You may need to play with these settings to tweak your isometric output.

Figure 93 Annotations

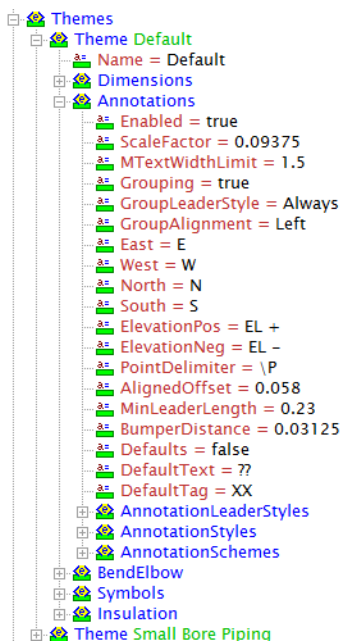

6.3.2.1 Annotation Leader Styles

AnnotationLeaderStyles define how our leaders look when calling out items. The leader styles will be referenced in AnnotationSchemes. Default leader styles are:

- AsNeeded
- AsNeededNonArrowed
- Always
- AlwaysCenter
- AlwaysCorner
- NoLeader
- AlwaysNonArrowed
- AlwaysCenterNonArrowed
- ExtensionLeader

Figure 94 Annotation Leader Styles

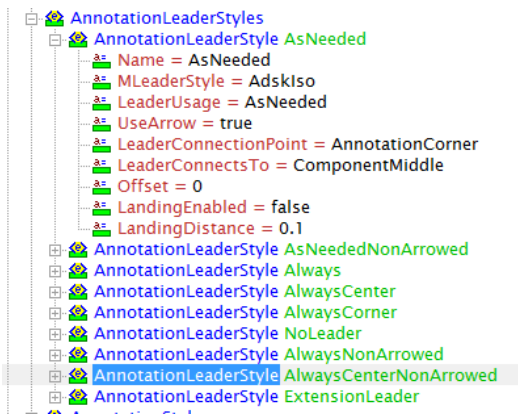

Each style consists of several parts; here are the options for each attribute:

Attribute	Description	Allowed Values
Name	Must be Unique among the Leaderstyles	Text
MLeaderStyle	A multi-leader style available in the isometric template	Text
LeaderUsage	When to use the leader	Always,DoNotUse,AsNeeded,Extension
UseArrow	Whether an arrow is on the leader	True/False
LeaderConnectionPoint	Where the leader connects to the annotation	AnnotationCorner,AnnotationMiddle,AnnotationCenter

Attribute	Description	Allowed Values
LeaderConnectsTo	Where on the component the leader points	ComponentMiddle,ComponentEnd
Offset	Offset distance from the component	Number
LandingEnabled	Whether the leader has a landing or not	True/False
LandingDistance	How long is the landing on the leader	Number

6.3.2.2 Annotation Styles

In addition to specifying leader behavior, AutoCAD Isometrics allows us to customize annotation labels. Annotation styles can have these attributes.

Attribute	Description	Allowed Values
Name	Unique Identifier	Text
TextStyle	The text style (from iso template) used for the annotation. With blocks, the text style comes from the attribute	Text
BlockName	A block from the IsoSymbolStyles.dwg	Text
ResizeBlock	Indicates how to re-size a block	Scale

6.3.2.3 Annotation Schemes

While the Annotation leader styles and annotation styles setup what annotations can look like in the iso, the annotation scheme chooses if, when and where to use the annotation on an iso. The Default theme includes several types of annotation schemes.

- Line number – for annotating your line display
- Property Breaker – for calling out breaks in line properties
- PropertyChange – For calling out changes in line properties
- Elevation – calls out elevation changes
- Component – individual component annotations
- Group Scheme – for labeling group of components (ie Flange, bolt, gaskets)
- Map – for labeling items with compound properties

Schemes have these attributes in common:

Attribute	Description	Allowed Values
Name	Unique Value	Text
AnnotationStyle	The text/block used for this annotation	An AnnotationStyle from above
Format	Order of properties populating our annotation	See referencing Fields in a format
Enabled	Use the annotation	True/False
Filter	When to apply the annotation	A filter name from the Filters section
Alignment	How is the annotation oriented	FlatHorizontal, FlatAligned,SkewAligned
Tag	The tag of the attribute if using a block annotation style	Attribute Name
Positioning	Where is the annotation placed relative to the drawing area	Anywhere, Above, Below
Placement	Where is the annotation placed relative to the object	Ends, Center, Along, Anchored

6.3.2.3.1 Referencing Fields in a format

Fields are placeholders or property names for values that will be used in the annotations. For example, in the ElevationScheme the Format uses \U+2104 {0}, where \U+2104 gets replaced by the center line symbol. The “{0}” placeholder is populated in the annotation from the coordinates. In this case, you cannot modify the property that gets put into the annotation. However, in the case of the other annotations, you can.

The MapScheme for InsulationWithTracing is a prime example of populating an annotation with Fields and Formatting. Examine the section under FieldMap. Under the top field section that has the Tag=XX, the Fields attribute specifies which properties are going to be used. In this case, two properties, INSULATION-SPEC and INSULATIONTHICKNESS will be included.

The next attribute format allows you to specify the text in which those properties appear. When placing the values, the program will look for {0} first and then substitute the first item in the Fields list, in this case INSULATION-SPEC. Then it will find the {1} and substitute the next item in our fields list, or INSULATIONTHICKNESS. By the format defined, the end result will be a hyphenated annotation that includes both properties.

Figure 95 Fields and Formats

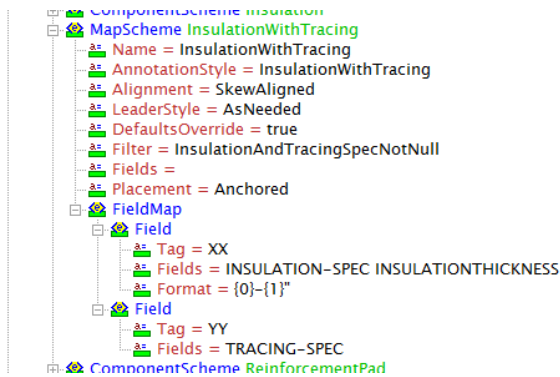

6.4 Key Concepts

6.4.1 Model Properties

Model properties are values that can come over from the model and be placed or referenced on the isometric. A partial list of the properties is available in the online help files under [model properties](#).

Additional properties may be found by examining the pcf file for a line, which is where the CO-ORDS property is listed.

Figure 96 PCF Model Properties

```

UNITS-BORE INCH
UNITS-CO-ORDS INCH
UNITS-WEIGHT LBS
UNITS-BOLT-DIA INCH
UNITS-BOLT-LENGTH INCH
PIPELINE-REFERENCE UserDefinedLine
DATE-DMY 03/21/13
PROJECT-IDENTIFIER
REVISION 0
AREA
PIPING-SPEC CS150
END-POSITION-NULL
CO-ORDS 390.4901 -16.0280 280.1341
END-POSITION-NULL
CO-ORDS 248.2749 -96.5075 204.8311
BOLT
CO-ORDS 317.0920 -96.5075 204.8311
BOLT-DIA 5/8
BOLT-ITEM-CODE CS150-8888-3.5
ERECTION-ITEM
BOLT-QUANTITY 8
BOLT-LENGTH 3.5
COMPONENT-ATTRIBUTE1 BOMCOLUMN_Material_
COMPONENT-ATTRIBUTE2 BOMCOLUMN_SCHClass_150
BOLT
CO-ORDS 307.9975 -96.5075 204.8311
BOLT-DIA 5/8
BOLT-ITEM-CODE CS150-8888-3.5
ERECTION-ITEM

```

6.4.2 Line Group Properties

Another important set of properties that are available are line group properties. These may be linked to the title block for adding additional iso information.

6.4.3 Project/Drawing Properties

Typically Plant 3d uses fields to populate properties from drawings or the project in a title block. However, due to the nature of isometrics, properties are set in normal block attribute when the drawing is created. Therefore, project/drawing properties are not live references to the current project.

6.4.4 Attribute Mapping

See [the title block attributes](#) section for details on mapped attributes.

7 Customization Examples

7.1 Modifying Dimension Cutoff

Some companies like the default setting that uses inches from 1" to 24" for lengths in the isometrics. However, for others, they want to start using the foot mark at 12 inches. You can modify the point at which AutoCAD Isometrics uses feet and inches in the dimensions by changing the Default theme.

To have the isometrics use the foot mark for under 24 inches, modify the ImperialDimensionInchCutoff value:

Figure 97 Imperial Dimension Inch Cutoff

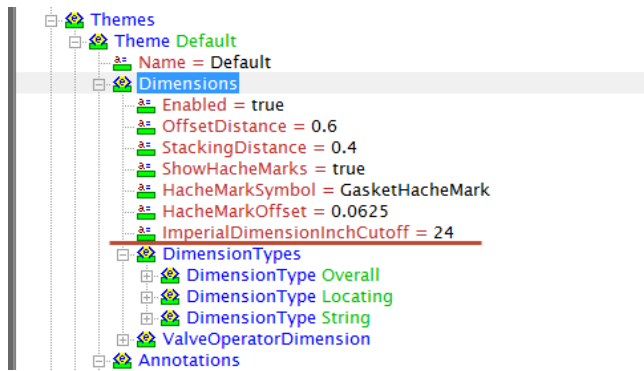

7.2 Modifying Isometric file Names

Previously, [populating format values with fields](#) was discussed. While in that section, the formatting referred to the annotation schemes, that concept is used elsewhere in the isoconfig.xml. Most notably, you can specify formatting options for the file name format and the drawing name format.

The file name format controls the name of the file that gets created by AutoCAD Isometrics. The Drawing Name format controls what will be displayed in the continuation callouts when the drawing is split.

Each of these formats contains the same sections, but can be configured differently. The sections are PrefixModelProperties, Sheet Number, and SuffixModelProperties. A partial list of available properties is available in the help files [under model properties](#). See [the Title Block Attributes](#) section for other properties available.

Figure 98 File Name Formatting



To include the project number in our iso file name, we need to make the following changes.

In the iso.atr, make sure the project number is mapped.

Figure 99 Mapped Project Number

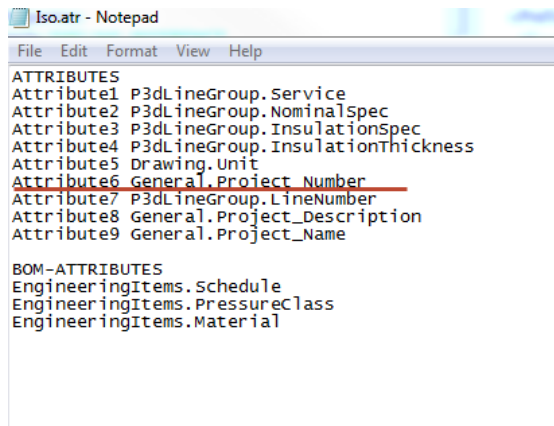

In the isoconfig.xml under FileNameFormat, Copy/Paste the ModelProperty under PrefixModelProperty, and set the first item's Name to Attribute6. Modify the delimiter if needed. Also, make sure a project number is in the project properties.

Figure 100 Modified PrefixModelProperty

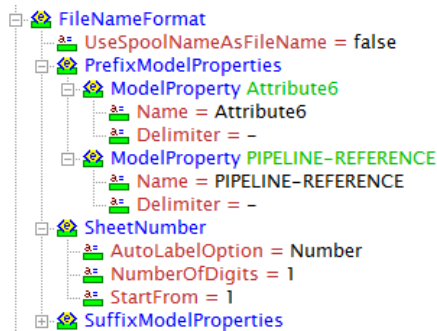
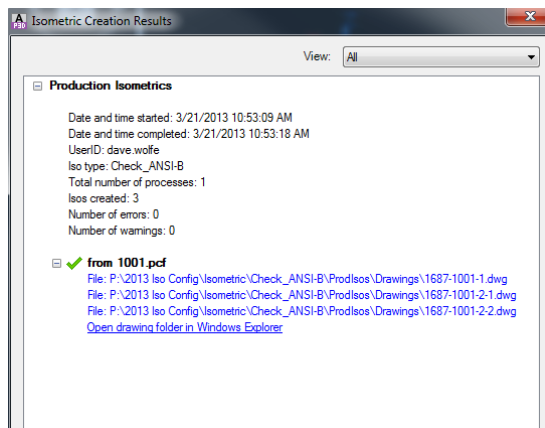

Figure 101 Iso File name with Project number



7.3 Using Lower Case Characters

Some clients may want to custom BOM mark number to include both lower and upper case, or to change the reduction size callout. The key variable that controls both of these capabilities is found under the Output section. The ForceUppcase setting, if true, will make everything on the iso uppercase which is the default behavior. By setting it to false, you can modify other options to include lower case characters.

Figure 102 Force Uppercase

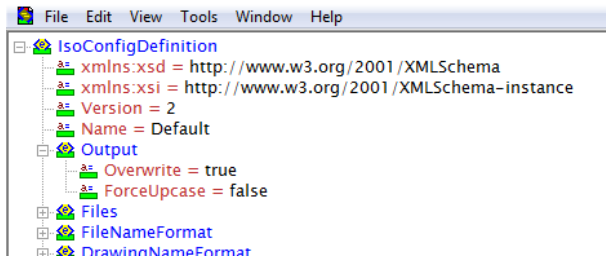

Under Data, the SizeDelimiter can be made lower case.

Figure 103 Size Delimiter

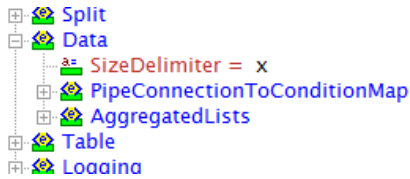

Also, within the Data section, the Index on an AggregatedList may include a character attribute which includes characters that are allowed as the index.

Figure 104 Index Characters

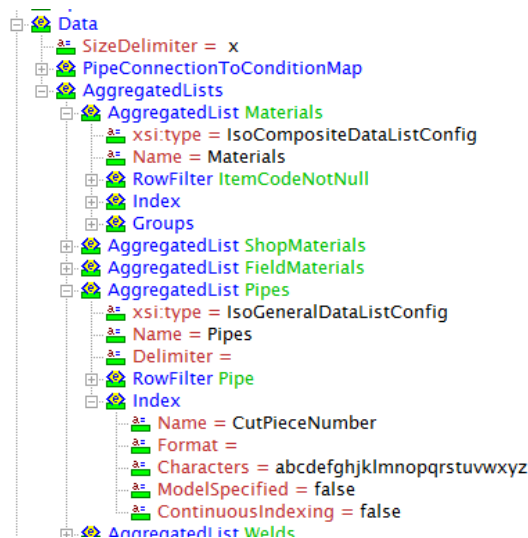
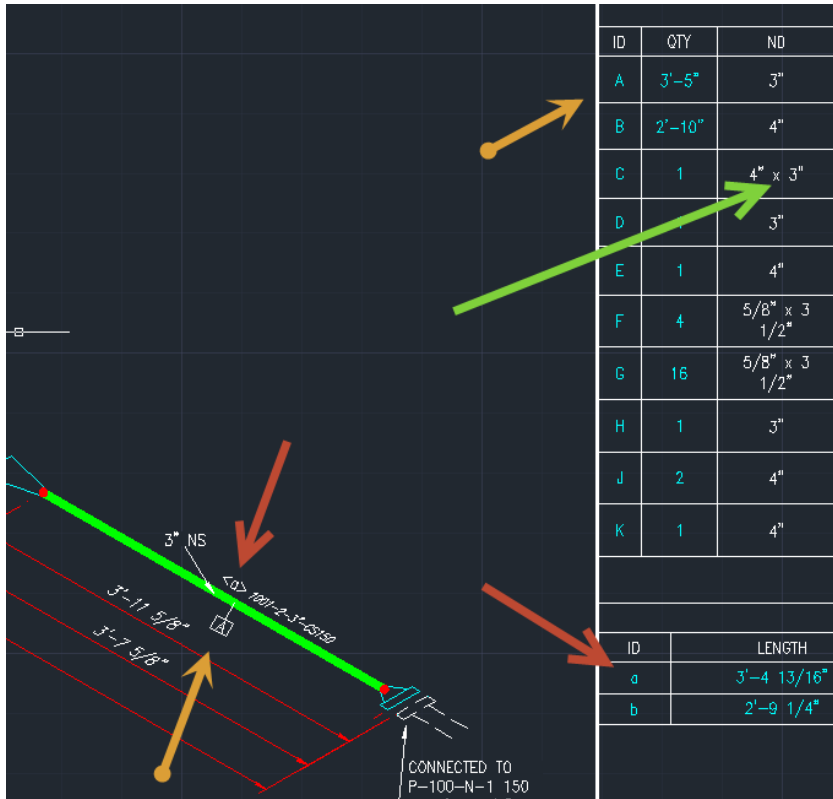

Figure 105 Lower Case options



The downside of turning of ForceUppcase is that inevitably within some catalog description lowercase letters were used. These will come through without being capitalized.

Figure 106 Lower Case BOM

E	1	4	WPB
F	4	5/8" x 3 1/2"	BOLT SET, RF, 150 LB, STUD BOLT
G	16	5/8" x 3 1/2"	BOLT SET, RF, 150 LB, STUD BOLT
H	1	3"	GASKET, SWG, 1/8" THK, RF, 150 LB, ASME B16.20, CS/PTFE
J	2	4"	GASKET, SWG, 1/8" THK, RF, 150 LB, ASME B16.20, CS/PTFE
K	1	4"	Ball Valve, Long Pattern, 150 LB, RF, ASME B16.10, ASTM A216 Gr WPB, Hand Lever

7.4 Turning Off Coordinates

To truly turn co-ordinates off, you must remove references to the CO-ORDS model property. If you find and replace the existing CO-ORDS value with CO-ORDS1, no coordinates will appear, and you'll be able to put them back if need. Most of the coordinates references are located within the Continuation/Connection Piping theme.

Removing the coordinates changing from this output:

Figure 107 Isometric with Coordinates

Figure 108 Removed Coordinates

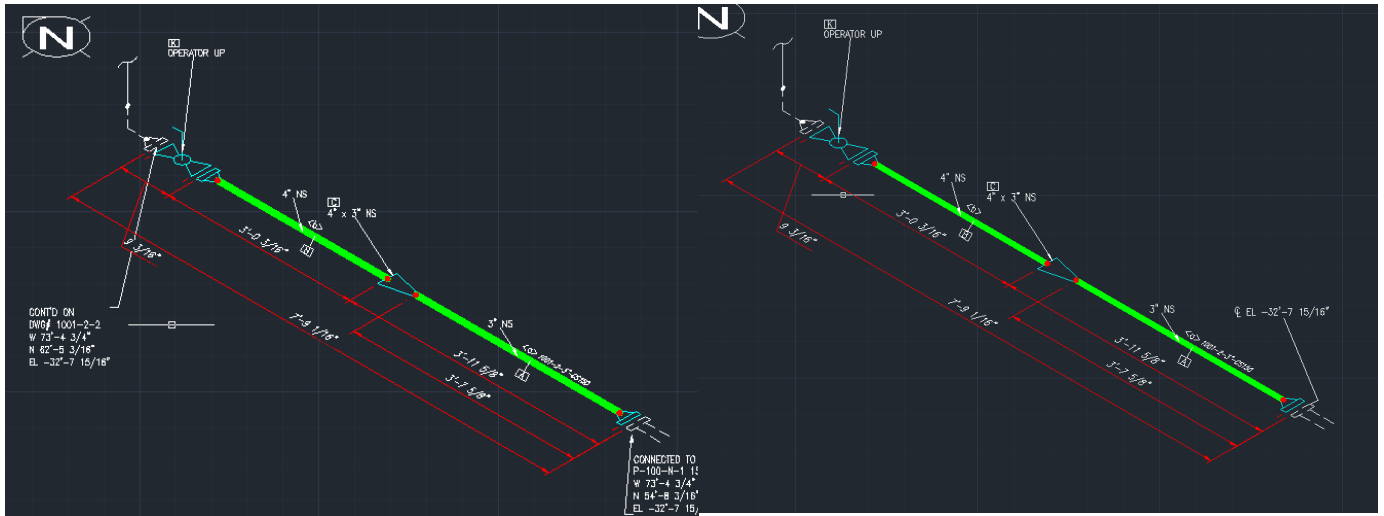

7.5 Changing the Line Number Callout

As mentioned in a [previous section](#), the Default theme contains a LineNumber Scheme. Much like the file and drawing format name, the line number scheme can contain multiple [field references and formatting](#).

Figure 109 Line Number Annotation

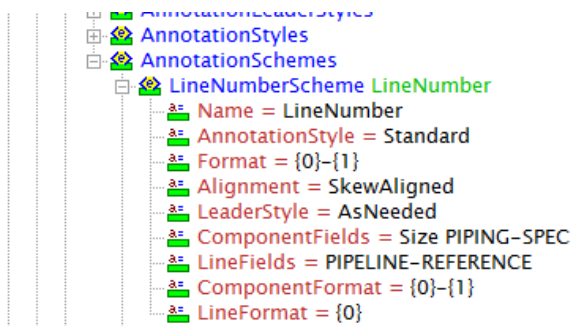
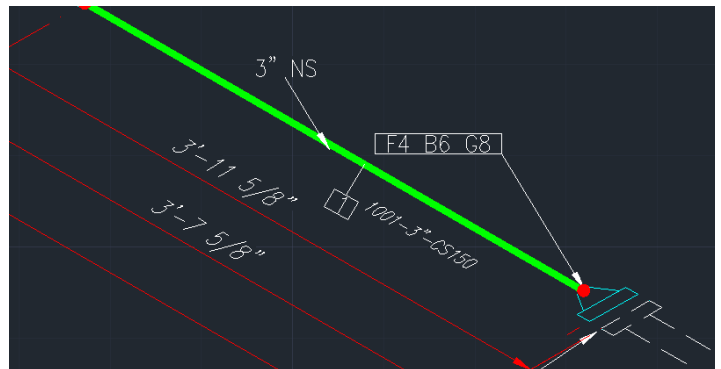

Figure 110 Default Line Number Annotation



The default line number annotation places the PIPELINE-REFERENCE first, and then the Size and the PIPING-SPEC.

The line annotation then, consists of three formats, the Format, the LineFormat, and the ComponentFormat.

The Component Format depends on the actual component being labeled. The Line Format pulls properties from the PipeLine Group, so any mapped property may be used here.

Within the Format attribute, the Line format is referenced first, {0}, and then the ComponentFormat {1}.

So, by setting the format to {1}, we can exclude the pipeline reference (1001).

Figure 111 Line Annotation with no Line Number

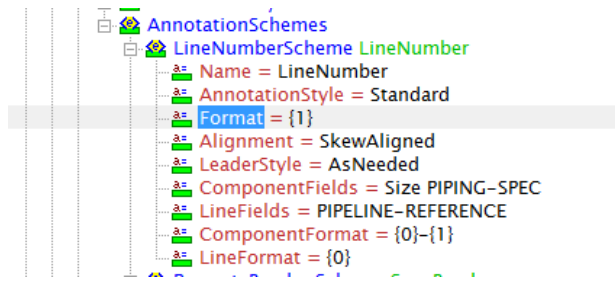
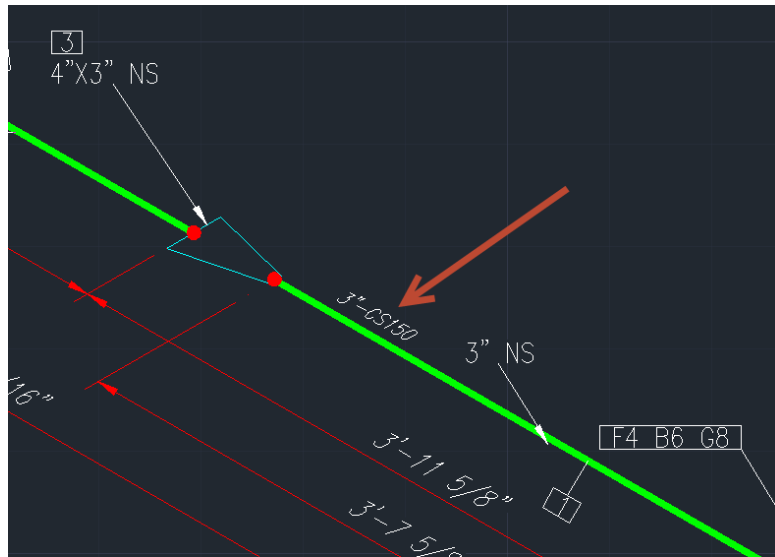

Figure 112 Isometric with Size Spec Line annotation



8 Using AutoCAD Isometrics

8.1 Production Workflow

In order to have success with modeling, you must follow a workflow that ensures the validity of the model. For best results, you should:

1. Plan an approximate route for your line in the model.
2. Route your line, placing inline items.
3. Validate your line against the P&ID (if available).
4. Walk the line down in either Navisworks or a rendered visual style.
5. Run an iso using production isometric.
6. Verify the isometric breaks appropriately and includes the proper components.
 - a. If the iso breaking in the wrong spots or doesn't show end connections, run the [test iso style](#) to locate out of place components.

Frequently, new users assume that if the pipe is in the model, an isometric will be generated properly. However, even the best pipers assign incorrect line numbers, forget to tag items, fail to connect items, or accidentally route into a steel member. By following the above steps, you can provide checks at several points along the way ensuring the validity of your model as well as ensuring a good design.

8.2 Figures

FIGURE 1 ISO STYLE SETTINGS	5
FIGURE 2 CREATE NEW ISO STYLE BUTTON	5
FIGURE 3 CREATE TEST_ANSI-B	6
FIGURE 4 COPYING A COMPONENTSCHEME	7
FIGURE 5 DUPLICATING A COMPONENTSCHEME	7
FIGURE 11 CHOOSING P&ID PROJECT DATA	10
FIGURE 12 EXPORTING PIPE LINE GROUP DATA.....	10
FIGURE 13 EXPORT ACTIVE NODE ONLY.....	10
FIGURE 14 SETUP TITLE BLOCK.....	10
FIGURE 15 TITLE BLOCK ATTRIBUTES NAVIGATION	10
FIGURE 21 DEFAULT THEME EDITING	13
FIGURE 22 DEFAULT THEME SECTIONS	14
FIGURE 23 SMALL BORE PIPING THEME	14
FIGURE 24 OVERRIDE THEME EDITING.....	15
FIGURE 25 CONTINUATION THEME XML	15
FIGURE 26 ELBOW.....	25
FIGURE 27 ELBOWREDUCING.....	25
FIGURE 28 BEND	25
FIGURE 29 BENDMITRE	25
FIGURE 30 ELBOW-180RETURN	26
FIGURE 31 BEND-180RETURN	26
FIGURE 32 TEE.....	26
FIGURE 33 TEEDBEND	26
FIGURE 34 REDUCERCONC	27
FIGURE 35 REDUCERECC.....	27
FIGURE 36 GASKET	27
FIGURE 37 FILTER-STRAINER.....	27
FIGURE 38 FILTER-ANGLE	28
FIGURE 39 CROSS.....	28
FIGURE 40 CAP	28
FIGURE 41 SCREWEDCAP	28
FIGURE 42 NIPOLET	29
FIGURE 43 FLANGE	29
FIGURE 44 FLANGAWN	29
FIGURE 45 FITTINGFLANGE.....	29
FIGURE 46 FLANGE-LINED.....	30
FIGURE 47 FLANGESCREWED	30
FIGURE 48 CLAMPEDFLANGE	30
FIGURE 49 3WAYVALVE.....	30
FIGURE 50 4WAYVALVE	31
FIGURE 51 VALVEANGLE.....	31
FIGURE 52 BALLVALVE	31
FIGURE 53 CHECKVALVE-ALT1.....	31
FIGURE 54 OPERATOR_HAND1.....	32
FIGURE 55 SUPPORT	32
FIGURE 56 ISO SYMBOL TYPE AND SKEY AT BOTTOM RIGHT.....	37
FIGURE 57 XML NOTEPAD 2007	39

FIGURE 58 FOXE.....	39
FIGURE 59 ISO CONFIGURATION EDITOR	40
FIGURE 60 DRAW AREAS IN THE ISOCONFIG.XML.....	41
FIGURE 61 DRAW AREA TOOLS	41
FIGURE 62 SKEW SETTINGS IN ISOCONFIG.XML	42
FIGURE 63 SKEW SETTINGS IN PROJECT SETUP	42
FIGURE 64 AVAILABLE TABLES.....	43
FIGURE 65 BOM TYPES.....	43
FIGURE 66 FABRICATION AND ERECTION SECTIONS	43
FIGURE 67 SIMPLE BOM	44
FIGURE 68 BOM WITH CATEGORY TITLE.....	44
FIGURE 69 TITLE BLOCK BOM WITH CATEGORIES.....	44
FIGURE 70 BOM WITH CATEGORIES	45
FIGURE 71 INDEPENDENT COLUMNS	45
FIGURE 72 ADDING THE ITEM CODE COLUMN.....	45
FIGURE 73 INCLUDING ITEM CODE FOR VALVES ONLY	45
FIGURE 74 BOM TABLE WITH VALVE CATEGORY AND ITEM CODE	46
FIGURE 75 PRODUCED ISO WITH ITEM CODE.....	46
FIGURE 76 ISO TITLE BLOCK ATTRIBUTES.....	47
FIGURE 77 ATTRIBUTE MAPPING.....	47
FIGURE 78 SPLITTING ISOMETRICS	48
FIGURE 79 DEFAULTSPLITPOINTS	48
FIGURE 80 MODEL SPLITTING	49
FIGURE 81 DATA SECTION.....	50
FIGURE 82 AGGREGATED LISTS.....	50
FIGURE 83 MODIFIED SIZE DELIMITER	50
FIGURE 84 BW CONDITION MAP	50
FIGURE 85 CUT PIECE WITH BVL CALLOUT	51
FIGURE 86 MATERIALS AGGREGATED LIST.....	51
FIGURE 87 TABLE SETUP.....	52
FIGURE 88 OVERFLOWSHEETLABELCONFIG	52
FIGURE 89 TITLEBLOCK SECTION	53
FIGURE 90 FILTERS	54
FIGURE 92 DEFAULT THEME DIMENSIONS.....	55
FIGURE 93 ANNOTATIONS.....	55
FIGURE 94 ANNOTATION LEADER STYLES	56
FIGURE 95 FIELDS AND FORMATS	59
FIGURE 96 PCF MODEL PROPERTIES.....	59
FIGURE 98 FILE NAME FORMATTING	61
FIGURE 99 MAPPED PROJECT NUMBER	62
FIGURE 100 MODIFIED PREFIXMODELPROPERTY.....	62
FIGURE 101 ISO FILE NAME WITH PROJECT NUMBER	62
FIGURE 102 FORCE UPPERCASE	63
FIGURE 103 SIZE DELIMITER.....	63
FIGURE 104 INDEX CHARACTERS	63
FIGURE 105 LOWER CASE OPTIONS.....	64
FIGURE 106 LOWER CASE BOM	64
FIGURE 107 ISOMETRIC WITH COORDINATES	65
FIGURE 108 REMOVED COORDINATES.....	65

FIGURE 109 LINE NUMBER ANNOTATION	65
FIGURE 110 DEFAULT LINE NUMBER ANNOTATION.....	65
FIGURE 111 LINE ANNOTATION WITH NO LINE NUMBER.....	66
FIGURE 112 ISOMETRIC WITH SIZE SPEC LINE ANNOTATION	66

Revision History

1.0

- *Added: Everything*